

EQE5660A-B
EQE5660A-S
EQE5600A-S

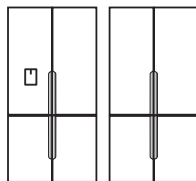

EN Refrigeration
HK 雪櫃

User Manual 2
使用手冊 2

Enjoy peace of mind. Register your appliance today.

Stay updated on better living services,
safety notices and shop for accessories.

1. Open the camera app on your smartphone and point at the QR code to scan

Product Registration QR code is located on the front of the door or internal side wall of your fridge.



2. Tap the notification or link to open the registration form
3. Complete your details and enjoy peace of mind

CONTENTS

1. SAFETY INFORMATION	3
2. DESCRIPTION OF THE APPLIANCE	5
3. INSTALLING YOUR NEW APPLIANCE	7
4. TEMPERATURE CONTROL	11
5. STORAGE FEATURES	17
6. AUTOMATIC ICE & WATER DISPENSER	20
7. GENERAL INFORMATION	22
8. FOOD STORAGE GUIDE	24
9. TROUBLESHOOTING	25
10. NOISES	29

WE'RE THINKING OF YOU

Thank you for choosing Electrolux. We have designed this product to make your life simpler and deliver impeccable performance for many years. Please spend a few minutes reading this document to get the best from your new Electrolux appliance.

Visit our website to:



Get usage advice or service information:
www.electrolux.com



Register your product for better service:
www.electrolux.com/support/register-warranty

CUSTOMER CARE AND SERVICE

Always use original spare parts.

When contacting our Authorised Service Centre, ensure that you have the following data available: Model, PNC, Serial Number.

The information can be found on the rating plate.

 Warning / Caution-Safety information.

 General information and tips.

 Environmental information.

Subject to change without notice.

1. SAFETY INFORMATION

Note: You must read these warnings carefully before installing or using the refrigerator. If you need assistance, contact your customer care centre. The manufacturer will not accept liability, should these instructions or any other safety instructions incorporated in this book be ignored.



WARNING

- It is essential the electric outlet is properly earthed to ground. Consult a qualified electrician if you are unsure.
- Do not use electrical appliances inside the food storage compartments of the appliance, unless they are of the type recommended by the manufacturer.
- Unplug the refrigerator before cleaning or moving it to avoid electric shock.
- Never unplug the refrigerator by pulling the electrical cord as this may damage it. Grip the plug firmly and pull straight out.
- If the power cord is damaged, it must be replaced by the manufacturer, its service agent or similarly qualified persons in order to avoid a hazard.
- Don't use a steam cleaner. If live components come into contact with condensing steam, they may short-circuit or cause an electric shock.
- Do not store explosive substances such as aerosol cans with a flammable propellant this appliance. If pressurised aerosol containers bear the word 'flammable' and/or a small flame symbol, do not store them inside any refrigerator or freezer. If you do so you may cause an explosion.
- Do not damage the refrigerant circuit
- This appliance contains insulation formed with flammable blowing gases. Avoid safety hazards by carefully disposing of this appliance.
- If you wish to discard this refrigerator, please contact your local authorities and ask for the correct method of disposal.
- When you dispose of your old refrigerators and freezers, remove any doors. Children can suffocate if they get trapped inside.
- When positioning the appliance, ensure the supply cord is not trapped or damaged.
- Do not locate multiple portable socket-outlets or portable power supplies at the rear of the appliance.



WARNING

R600a refrigerant warning



This appliance contains flammable R600a refrigerant. Avoid safety hazards by carefully installing, handling, servicing and disposing of this appliance.

- Ensure that the tubing of the refrigerant circuit is not damaged during transportation and installation.
- Leaking refrigerant may cause eye injuries or ignite.
- The room for installing appliance must be at least 1m³ per 8g of refrigerant. The amount of refrigerant in the appliance can be found on the rating plate inside the appliance.
- If you are unsure of the refrigerant check the rating plate inside the refrigerator compartment
- It is hazardous for anyone other than an Authorised Service Person to service this appliance. In Queensland Australia the Authorisation Service Person MUST hold a Gas Work Authorisation for hydrocarbon refrigerants to carry out servicing or repairs which involve the removal of covers.
- Keep ventilation openings in the appliance enclosure or in the built-in structure, clear of obstruction.
- Do not use mechanical devices or other means to accelerate the defrosting process, other than those recommended by the manufacturer.

GENERAL WARNINGS

Read the following carefully to avoid damage or injury. It is important to use your refrigerator safely. Check these safety points before using your refrigerator.

- The appliance must be plugged into its own dedicated electrical outlet.
- The plug must be accessible when the refrigerator is in position.
- It is essential the powerpoint is properly earthed to ground. Consult a qualified electrician if you are unsure.
- Don't use extension cords or adapter plugs with this refrigerator.
- If the supply cord is damaged, it must be replaced by the manufacturer, its service agent or similarly qualified persons in order to avoid a hazard.
- Unplug the appliance before cleaning and before changing the light bulb(when fitted) to avoid electric shock.
- Never unplug the refrigerator by pulling the electrical cord as this may damage it. Grip the plug firmly and pull straight out.
- Choose a location for your refrigerator that isn't too cold. The ambient room temperature should be above 10°C.
- Stand your refrigerator in a dry place avoid areas of high moisture or humidity.
- Don't put the refrigerator in frosty or unprotected areas like a garage or on the verandah.
- Don't plug your refrigerator into a timer fitted to the powerpoint.
- Do not put the refrigerator in direct sunlight, near stoves, fires or heaters.
- Do not put the refrigerator on an uneven surface.
- Do not store flammable materials on or under the appliance, e.g. aerosols.
- Do not store explosive substances such as aerosol cans with a flammable propellant in this appliance.
- Never store fizzy drinks in the freezer compartment.
- Never try to repair the refrigerator yourself, only use a qualified or authorised service person for repairs.

- Never use electric heaters or dryers to defrost the freezer because you can receive an electric shock.
- When transporting and installing the refrigerator, care should be taken to ensure that no parts of the refrigerating circuit are damaged.
- When installed correctly, your refrigerator should:
 - Have adequate space at the back and sides for air circulation.
 - Be vertically aligned to the surrounding cupboards.
 - Have doors that will self-close from a partially open position.
- The appliance is not to be used by persons (including children) with reduced physical, sensory or mental capabilities, or lack of experience and knowledge, unless they have been given supervision or instruction concerning use of the appliance by a person responsible for their safety.
- Children being supervised not to play with the appliance.

NOTE: You must read these warnings carefully before installing or using the refrigerator. If you need assistance, contact your Customer Care Department. The manufacturer will not accept liability, should these instructions or any other safety instructions incorporated in this book be ignored.



ENVIRONMENTAL INFORMATION

This appliance is intended to be used in household and similar applications such as,

- The kitchen areas in shops, offices and other working environments;
- Farm house and by clients in hotels, motels and other residential type environments;
- Bed and breakfast type environments;
- Catering and similar non-retail applications;

2. DESCRIPTION OF THE APPLIANCE

2.1 QUATTRO FRENCH DOOR WITH ICE & WATER REFRIGERATOR FEATURES

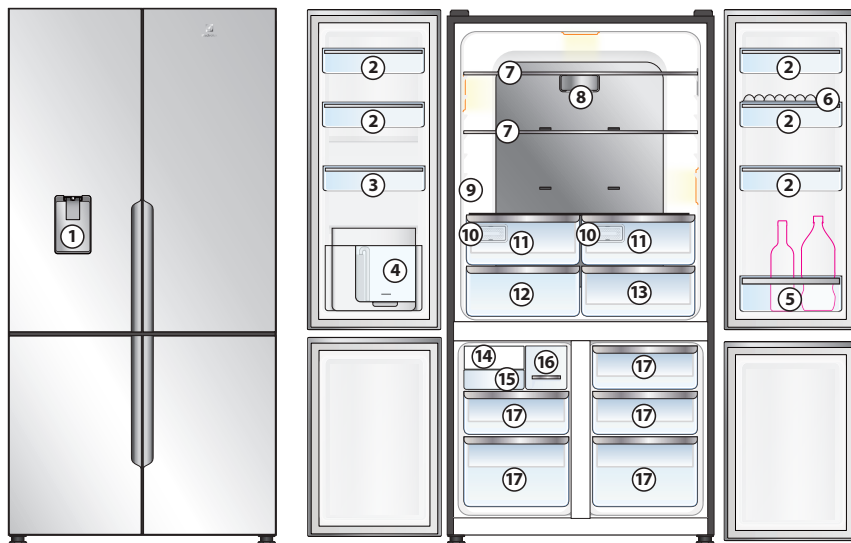

EQE5660 Illustrated

- | | | | |
|----------|--|-----------|-------------------------|
| 1 | Water Dispenser Trigger | 10 | Anti-Oxidant Filter |
| 2 | Door Bins* | 11 | TasteLockAuto Drawer |
| 3 | Door Bin Small* | 12 | TasteSealPlus Drawer |
| 4 | Water Tank | 13 | Drawer Deli |
| 5 | Bottle Storage Bins | 14 | Automatic Ice Maker |
| 6 | Egg Tray | 15 | Ice Storage Small |
| 7 | Glass shelves | 16 | Ice Storage Bin Freezer |
| 8 | Air Filter | 17 | Freezer Drawer |
| 9 | UI Control Panel (on the left side wall) | | |

NOTE:

* Door bin (3) is the slightly smaller than Door bin (2),
Position must be installed as per above picture.

2.2 QUATTRO FRENCH DOOR REFRIGERATOR FEATURES

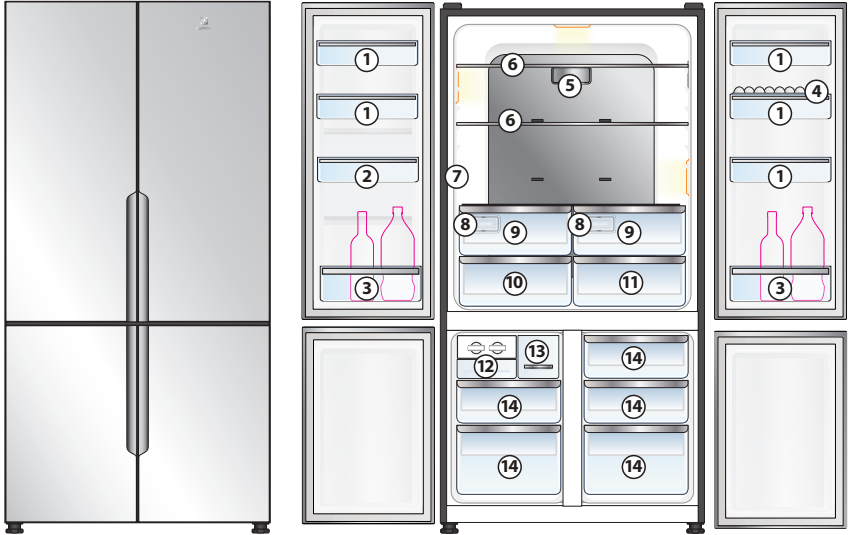

EQE5600 illustrated

- | | | | |
|---|--|----|-------------------------|
| 1 | Door Bins* | 8 | Anti-Oxidant Filter |
| 2 | Door Bin Small* | 9 | TasteLockAuto Drawer |
| 3 | Bottle Storage Bins | 10 | TasteSealPlus Drawerr |
| 4 | Egg Tray | 11 | Drawer Deli |
| 5 | Air Filter | 12 | Twist & Serve Ice Bin |
| 6 | Glass shelves | 13 | Ice Storage Bin Freezer |
| 7 | UI Control Panel (on the left side wall) | 14 | Freezer Drawer |

NOTE:

* Door bin (2) is the slightly smaller than Door bin (1),
Position must be installed as per above picture.

3. INSTALLING YOUR NEW APPLIANCE

Unpacking



ENVIRONMENT

Most of the packing materials are recyclable. Please dispose of those materials through your local recycling depot or by placing them in appropriate collection containers.

Important – check for any damages or marks. If you find the refrigerator is damaged or marked, you must report it within 7 days should you wish to claim for damage/ marks under the manufacturers warranty. This does not affect your statutory rights.

Clean your refrigerator thoroughly following the instructions in the “Cleaning” section and wipe off any dust that has accumulated during shipping.

Locating the refrigerator



CAUTION

Automatic aerosol systems (such as insect control) should not be located adjacent to the product as the spray may cause long term damage to the external plastics of the appliance.

Do not put the refrigerator in a location that is too cold or is unprotected, for example in a garage or on a veranda. The ambient temperature should be above 10°C.

Put the refrigerator in a dry place avoiding areas of high moisture or humidity.

Ensure the refrigerator is located on an even surface.

Installing your refrigerator

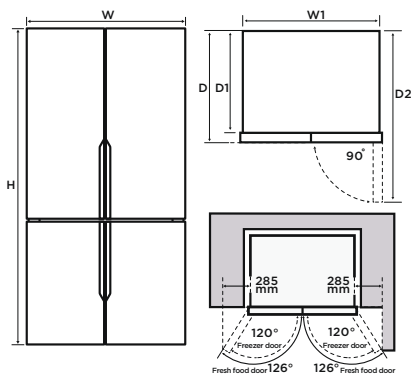

Product Dimensions

Total width (W)	mm	896
Total depth (D)	mm	726
Maximum height (H)	mm	1795
Cabinet width (W1)	mm	890
Cabinet depth (D1)	mm	640
Depth door open 90° (D2)	mm	1104

When positioned in a corner area, spacing of at least 285mm on the hinge side will allow the doors to open enough to enable the removal of bins and shelves.

Installation options for optimal aesthetics :

Minimum side clearance kitchen cabinet

Fridge must sit 10mm proud of kitchen cabinetry.

Minimum cabinetry opening (WxDxH) :
900mm x 649mm x 1800mm

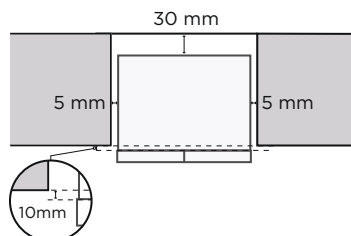

Front of fridge body in line with kitchen cabinet

Side clearance must be 25mm either side of fridge body, to have the fridge doors sitting proud of the kitchen cabinetry.

Minimum cabinetry opening (WxDxH) :
940mm x 659mm x 1800mm

Note : Spacers supplied to assist

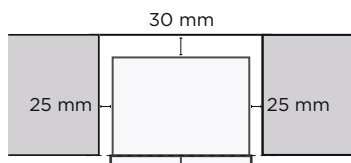

Fridge door flush with the cabinetry

Side clearance must be 90mm either side of the fridge, to have the fridge doors sitting flush with the kitchen cabinetry.

Minimum cabinetry opening (WxDxH) :
1070mm x 741mm x 1800m

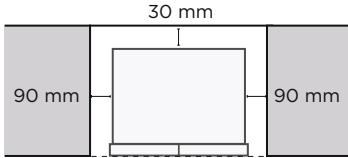

Note : Top gap all 5 mm.

1. Roll the refrigerator into place. The rollers are designed for forward or backward movement only. They are not castors. Moving the refrigerator sideways may damage your floor and the rollers. Before moving your refrigerator ensure height adjusting nut and the stability foot are fully wound up off the floor.
2. Wind the large height adjusting nut under door hinge down until the refrigerator is tilted back by 10mm (see diagram).

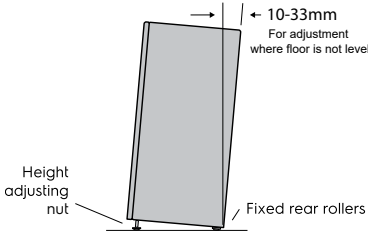

3. Wind the large height adjusting nut on the handle side down until the refrigerator is level and stable. If you have difficulty winding the nut or height adjusting foot down, have someone tilt the refrigerator back so you have better access.

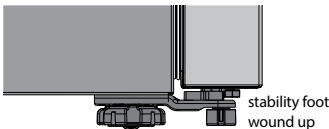

4. Check the alignment of the refrigerator to the surrounding cupboards to see if it is level. You can adjust the level as detailed in step 2 and 3.

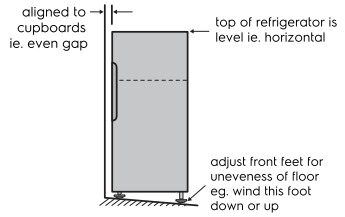

5. If you find your refrigerator rocks from corner to corner, it means your floor is uneven. Find a piece of plastic or hardboard etc. and pack it firmly under the roller.
6. You may now need to fine-tune the installation by repeating steps 3, 4 and 5.
7. When you have the appliance in its final position, it needs to be stabilised. Wind the stability foot under the door hinge down to the floor until it just makes contact with the floor. Lift the front of the appliance to take the weight off the stability foot, then turn it half a turn further to ensure firm contact with the floor. Wind the large height adjusting nut back up to ensure all the weight is now on the front stability foot. Wind the large height adjusting nut back up to ensure all the weight is now on the front stability foot.

Front view

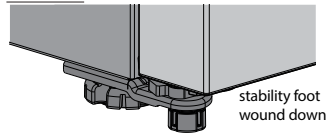

8. Repeat step 7 for the stability foot on the handle side. Whenever you need to move the appliance, be sure to wind the feet back up so that the appliance can roll freely and be sure to reset it when reinstalling.
9. Plug your refrigerator straight into its own power point and never use a double adapter. If you need to roll the refrigerator to get to the plug, remember to raise the stability foot first.
10. Before you put any food in your refrigerator, it's recommended you leave it on for 2 or 3 hours to check it is running properly.

Door opening

Your refrigerator should be positioned to allow easy access to a counter when removing food. For best use of refrigerator drawers and freezer baskets, the refrigerator should be in a position where both can be fully opened.



WARNING LED lighting

Your appliance is fitted with long life LED lighting. In the unlikely event the LED lights should fail, then the LED lights should be serviced by the service agent, to avoid a safety hazard. Refer to the warranty page for contact details.

Cabinet Leveling & Refrigerator Door Alignment (if necessary)

- All four corners of the cabinet must rest firmly on the floor
- The front should be slightly elevated to ensure that doors close and seal properly.
- Doors should align with each other and be level.

Most of these conditions can be met by raising or lowering the adjustable front rollers.

To level the cabinet using the front rollers:

1. Lower anti-tip legs until they are both touching the floor. Use a pair of pliers to adjust.

To raise: turn leg clockwise.
To lower: turn leg counterclockwise.

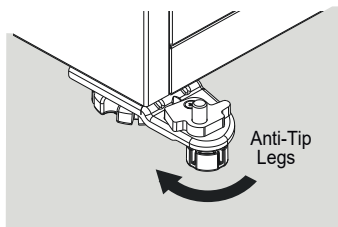

2. Ensure both doors are bind-free with their seals touching the cabinet on all four sides and that cabinet is stable.

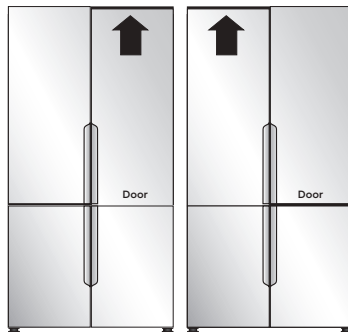

Flipper Mullion

Adjust Flipper Mullion for proper connection with the mullion guide by ensuring the flipper mullion is folded and perpendicular to the fresh food door. If the mullion guide is not in the correct position, it could prevent the door from closing completely.

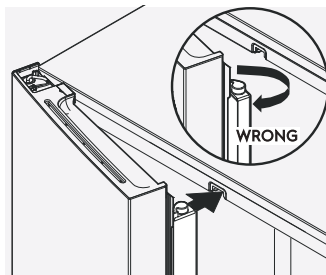

Air filter installation

1. Remove air filter cover.
2. Remove plastic bag from air filter and put air filter into air filter cover.
3. Then install air filter cover with filter on multiflow.

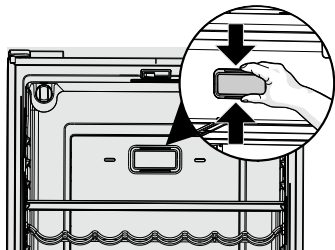

NutriPlus™ (Anti-Oxidant Filter)

Installing Filter Cartridge

Your filter can be found in the crisper. To enjoy the full benefit of NutriPlus™, it is important to install it after turning on the refrigerator. For installation, please follow the following instruction.

1. Remove plastic wrap.
2. Insert the packet into the holder in the side of crisper.

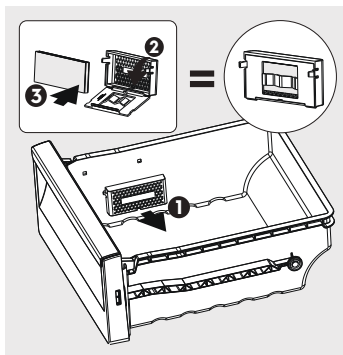

4. TEMPERATURE CONTROL

The following pages explain the various functions of the user interface to help you better understand how to get the most out of your new refrigerator.



IMPORTANT

NOTE: When you set a temperature, you set an average temperature for the whole refrigerator cabinet. Ensuring that you make only small adjustments and wait at least 24 hours to see if the new temperature is correct to your liking.

Checking the softness of ice cream is a good indication that your freezer is the right temperature, while checking the temperature of water kept in the refrigerator is a good way of checking the temperature of the food compartment.





Temperatures inside each compartment may vary, depending on how much food you store and where you place it.

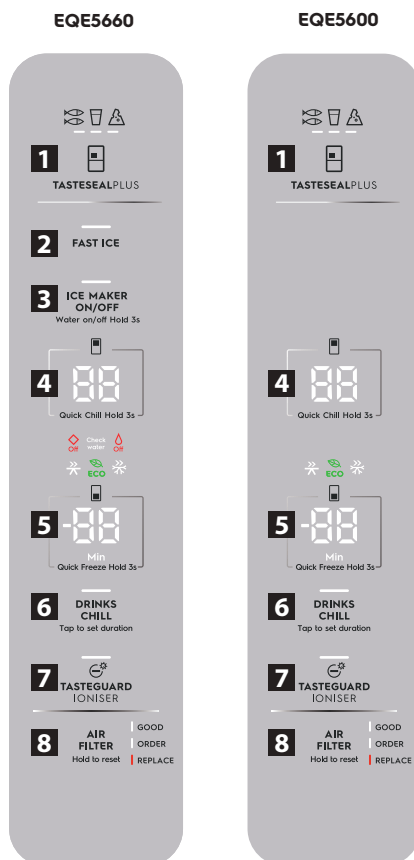



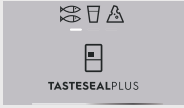

High or low room temperature may also affect the actual temperature inside the refrigerator.



4.1 Functions of the user interface



- 1 TasteSeal Plus Control
- 2 Fast Ice Button
- 3 Auto Ice Maker Control
- 4 Fridge Temp Control
- 5 Freezer Temp Control
- 6 Drinks Chill Button
- 7 Tasteguard Ioniser
- 8 Air Filter Reset Button

Function	Icon	Operation (depending on model)
<p>1 TasteSeal Plus Control</p>	<p>Meat & Fish</p>  <p>Cold Drinks mode</p>  <p>Deli snack mode</p> 	<p>Tap on TasteSealPlus button, Activates the next mode. The LED of the next mode lights up.</p> <p>TasteSeal plus has 3 temperature modes:</p> <ul style="list-style-type: none"> -2°C Meat & Fish -0°C Cold Drinks 3°C Deli snack
<p>2 Fast Ice Botton</p>		<p>Tap on Fast ice button.</p> <p>When Fast ice is ON, the Fast Ice indicator lights up. When Fast ice is OFF, the Fast ice indicator turns off.</p> <p>When Fast Ice is on, the compressor will run continuously for 24 hours. Fridge and TasteSealPlus compartment continue to run at set temperature.</p> <p>Fast ice auto turn off on either of this condition:</p> <ul style="list-style-type: none"> - 24 hours has elapsed - Freezer temp is adjusted to -23°C <p>NOTE:</p> <p><i>*Quick Freeze and Fast Ice cannot be activated at the same time. If Quick Freeze is ON, Fast ice cannot be activated.</i></p> <p><i>**When ice bin is full - Fast ice will not be deactivated. Auto Ice maker will stop working but Fast ice 12 hours counter continus to countdown.</i></p> <p><i>Whenever ice bin level drops, Auto Ice maker will continue to make ice with Fast ice turn on.</i></p>

Function	Icon	Operation (depending on model)
<p>3 Auto Ice Maker Control</p>	 <p>Ice Off Alert indicator</p>  <p>Water Off Alert indicator</p> 	<p>Tap on Ice Maker on/off button.</p> <p>When Ice maker is ON, the button LED lights up . When Ice maker is OFF, the button LED turns off. Ice Off alert lights up.</p> <p>Press and hold on Ice Maker On/Off button for 3 secods.</p> <p>When it is ON, water can be dispensed when the water dispenser paddle is pressed.</p> <p>When it is OFF, water cannot be dispensed when the water dispenser paddle is pressed.</p>
<p>4 Fridge Temp Control</p>		<p>Taps on the display to cycle through the temperature range supported by the Fridge.</p> <p>From 7°C To 1°C Default 4°C</p>
<p>5 Freezer Temp Control</p>		<p>Taps on the display to cycle through the temperature range supported by the Freezer</p> <p>From -14°C To -23°C Default -18°C</p>
<p>6 DrinksChill</p>	<p>Drinks Chill timer indicator</p> 	<p>The Drinks Chill timer is used to quickly chill a bottle inside the freezer compartment and to warn the user when it ends.</p> <p>Tap on Drinks Chill button, Freezer display shows 20 , "Min" and Drink Chill LED turns on.</p> <p>The timer option is from 20 minutes and the user can add time in 5 min intervals up to 45 minutes. After it starts the timer will show the countdown minute by minute.</p> <p>NOTE: <i>When timer countdown is in progress, the timer duration cannot be adjusted. User will need to deactivate Drinks Chill and activate Drinks chill again to set a new timer.</i></p>

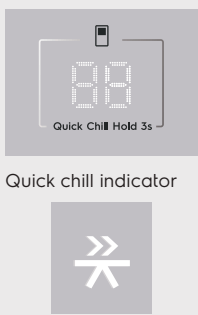
Function	Icon	Operation (depending on model)
<p>7 Tasteguard Ioniser</p>		<p>Tap on Ioniser button.</p> <p>When Ioniser is ON, Ioniser button LED turns on. When Ioniser is OFF, Ioniser button LED turns off.</p> <p>Ionizer is a device designed to reduce the bacteria level inside the refrigerator helping to extend food preservation time.</p> <p>It creates ozone while operating and it's important to keep the amount of ozone inside the safety limits (0.1ppm), therefore ionizer operation will follow a simple ON/OFF logic.</p> <p>Ioniser do not affect ECO status. ECO indicator will remain on when Ioniser is turned On.</p> <p>Deactivating Ioniser:</p> <ul style="list-style-type: none"> - By tapping on Ioniser button to turn OFF - When Holiday mode is set <p>NOTE</p> <ul style="list-style-type: none"> - Ionizer will stop operating during if the doors are opened and restart automatically when the door are closed. - Ionizer will stop operating during defrost process and restart automatically once defrost is finished.
<p>8 Air Filter Alert and Reset</p>		<p>"GOOD" LED turns on is mean the filter used for 0-4 months.</p> <p>"ORDER" LED turns on is mean the filter used for 5 months , to remind user to order new water filter.</p> <p>"REPLACE" LED turns on is mean the filter used for 6 months,</p> <p>Press and hold Air filter for 3 seconds to reset. Status will reset to GOOD.</p>
<p>Quick Chill Control</p>	 <p>Quick chill indicator</p>	<p>Press & Hold on Fridge digits for 3 seconds. Tap on Fridge digits to adjust temperature.</p> <p>When Quick chill is ON, the Quick chill indicator lights up.</p> <p>When Quick chill is OFF, the Quick chill indicator turns off.</p> <p>Use the Quick Chill when you add a large amount of food to the refrigerator compartment after grocery shopping or to quickly cooled your drink. When Quick chill is on, the cold air circulate into the refrigerator to temporarily reduce the temperature to 1°C for 6 hours, Freezer compartment continue to run at set temperature.</p> <p>Quick chill auto turn off on either of this condition:</p> <ul style="list-style-type: none"> - 6 hours has elapsed - Fridge temp is adjusted

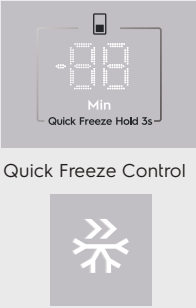
Function	Icon	Operation (depending on model)
Quick Freeze Control	 <p>Quick Freeze Control</p>	<p>Press & Hold on Freezer digits for 3 seconds. Tap on Freezer digits to adjust temperature.</p> <p>When Quick freeze is ON, the Quick Freeze indicator lights up.</p> <p>When Quick freeze is OFF, the Quick Freeze indicator turns off.</p> <p>Use the Quick freeze function when you add a large amount of food to the freezer compartment after grocery shopping, to speed up the freezing process. When Quick freeze is on, the compressor will run continuously for 6 hours. Fridge compartment continue to run at set temperature.</p> <p>Quick freeze auto turn off on either of this condition:</p> <ul style="list-style-type: none"> - 6 hours has elapsed - Freezer temp is adjusted to -23°C <p><i>NOTE: Quick Freeze and Fast Ice cannot be activated at the same time. If Fast ice is ON, Quick Freeze cannot be activated.</i></p>

4.2 Alert and Alarms

Door Alarm

When any of the door is left open for 2 minutes. The alarm will sound, and all LEDs that are currently on.

- The alarm is turned off by closing the door or resetting the countdown by pressing any key on the control panel.

High Temperature alert

In the event of high temperature condition, audio alarm is played every 10 seconds until the alert is acknowledged.

The alarm by pressing any key on the control panel.

Display and blink "HI" in the correspondent compartment display, whichever is in the high temperature condition.



High Temp indicator on Fridge display



High Temp indicator on Freezer display

ECO indicator

Eco mode indicator will light up automatically to 100% when the fridge and freezer compartments are set within a temperature range.

Fridge range: 4°C to 7°C

Freezer range: -18°C to -14°C

Selecting any of these mode: Quick Freeze, Quick Chill, Fast Ice or Drinks Chill will deactivate the Eco mode, the Eco icon will fade.



Air Filter Alert and Reset

Air Filter alert warns user that the Air filters have to be changed as soon as possible.

When air filter is used for 6 months since the last filter reset, the LED "Replace" will automatically turn ON.

Note:

1. Users could reset the filter when alert is not visible. Play tone_Confirm once it is reset.
2. LED, air filter remains visible during sleep mode, except when door is closed.

Check water Alert (EQE5660 model only)

When water tank is empty, the Ice maker senses the lack of warm water feeding in, and will turn off the ice maker.

Check water

This trigger will also displays the "Check water alert". The intention is the alert user that Ice maker has been turn off due to the lack of water.

The alert can be dismissed by turning on Ice maker. If no water is detected again, ice maker will be turn off again, and the check water alert turns on.

Error codes

Both Fridge & Freezer displays are used to communicate problems by code.

When error codes are displayed in the numeric display, the unit requires service attention.

"Er" shows up on Fridge display



Various error codes on Freezer display



Error code table	
Communication error	CE
FZ Cavity NTC	T1
FZ Evaporator NTC	T2
FF Cavity NTC	T3
Third cavity NTC	T5
FZ Ice maker NTC	T8

5. STORAGE FEATURES

Glass shelves

To remove the shelves, gently pull them forward until the shelf comes clear of the shelf guides.

To return the shelf, make sure there is nothing behind that may obstruct movement. Gently push the shelf, into the cabinet and back into position.

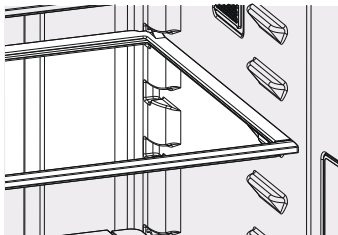

CAUTION

To avoid personal injury or property damage, handle tempered glass shelves carefully. Shelves may break suddenly if nicked, scratched, or exposed to sudden temperature change. Allow the glass shelves to stabilize to room temperature before cleaning. Do not wash in dishwasher.

Drawer

Your refrigerator includes a variety of storage drawers.

Crisper (with automatic humidity control)

Crisper drawers are designed for storing fruits, vegetables, and other fresh produce. Crispers have an auto humidity control (with replaceable membrane) on the back of each crisper under the humidity control cover.

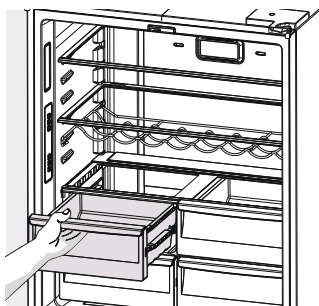

Opening the Crisper Drawer

To remove the auto humidity control membrane:

1. Reach to back of humidity control cover.
 2. Pull up on cover.
 3. Pull cover towards back of cabinet and remove.
 4. Replace humidity membrane.
 5. Replace cover by reversing the steps above.
- Repeat for both crispers.

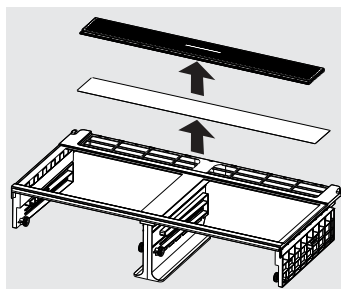

Remove the auto humidity control membrane



IMPORTANT

It's not required to replace the Auto humidity membrane unless it becomes damaged or ruined. If the membrane becomes soiled or dirty, it can be washed with soap and water. Ensure membrane is dry before putting back in crisper drawer. Please contact our service provider when need to replace your AHC membrane.

To remove the crisper for cleaning:

1. Pull the drawer out until it stops.
2. Lift the front slightly and remove the drawer.

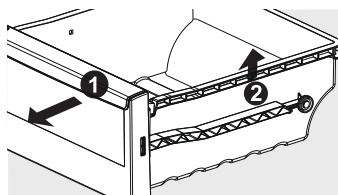

Removing Crisper

Doors

Storage bins

The doors to your fresh food compartment use a system of modular storage bins. All of these bins are removable for easy cleaning. Bins can be adjusted to your needs.

Door bins are ideal for storing jars, bottles, cans, and large drink containers. They also enable quick selection of frequently used items.

To remove the door bin:

1. lift and unlock from lugs to remove.
2. Replace by lift up and push bin down until the support lugs lock it in place.

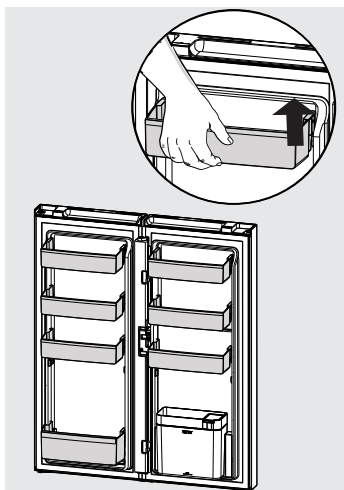

Removing door bin

Water Tank



CAUTION

BEFORE REMOVE; to empty the water in the tank.

To remove the water tank and disassembly cleanable parts follow these steps:

1. Life up water tank until locking release.
2. Pull water tank forward.

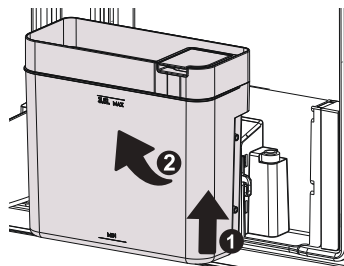

Removing water tank

3. Remove water tank lid (1), water tank tube (2) and filter (3).

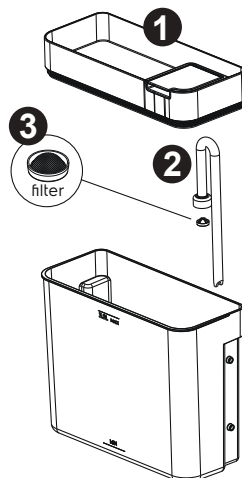

Disassembly water tank

Reverse the step to assembly the water tank and return to its place. Reverse the step to assembly the water tank and return to its place.

NOTE: The water tank for EQE5660 model only

Freezer storage

To remove freezer drawers:

All freezer drawers are removable.

1. Open doors completely to gain access to drawers.
2. Pull the drawer to the stopper. Lift up and pull to remove it from the cabinet.
3. Reverse the steps to reinstall drawer.

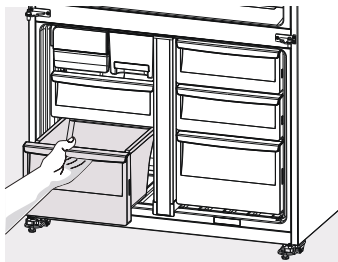

Removing Freezer Drawer

Twist & Serve Ice Bin (EQE5600 model only) :

1. Prior the first use clean the ice tray.
2. Fill the water up to max level of the ice tray.

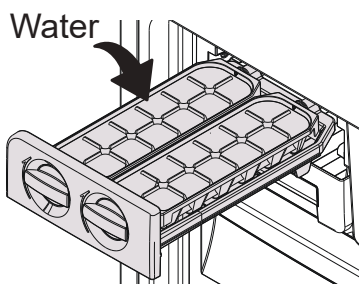

3. Put the ice tray in place.
4. Rotate ice twist clockwise to release the ice from ice tray.

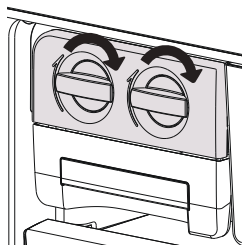

6. AUTOMATIC ICE & WATER DISPENSER

NOTE: The Automatic ice&water for EQE5660 model only

Using the ice maker after installation

The automatic ice making function pumps water from the water tank located in the refrigerator and dispenses it into the automatic ice maker in the freezer.

The ice will then be dropped into the ice bin located beneath the ice maker. If the water tank is empty or lower than level, the ice maker will automatically turn off after 3 attempts at pumping water from the tank. The ice maker indicator on the user interface shows the operational status of the ice maker (Refer control instructions).

Refilling the water tank

- The water tank must be placed on the door.
- Pour potable water through the funnel at the lid of water tank.
- Ensure that ice maker and dispenser is switched on.

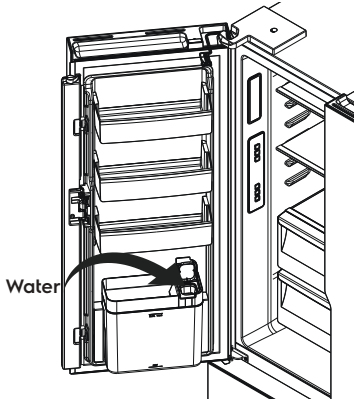

Priming the water supply system

1. Begin filling the system by pressing and holding a drinking glass against the dispenser.
2. Keep the glass in this position until water comes out of the dispenser. It may take about 1½ minutes.
3. Continue dispensing water for about four minutes to flush the system and plumbing connections of any impurities (stopping to empty the glass as necessary).

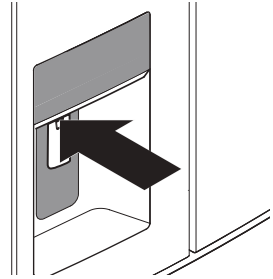

Note: The water dispenser has a built-in device that shuts off the water flow after three minutes of continuous use. To reset this shut-off device, simply release the dispenser paddle.



CAUTION

Do not fill the Water tank with anything other than clean water (Filtered or Mineral water). Soft drink, juice, tea or hot water etc, can damage your automatic icemaker. The Water tank can withstand a maximum water temperature of 60°C



Tip and Useful Information

Remove and clean ice bin and water tank once a month, discarding unused ice and water. This will ensure fresh ice and smooth operation of your icemaker. Make sure your refrigerator is level to avoid uneven ice cubes.

Turning the ice maker on and off



IMPORTANT

Your ice maker is turned on at the factory so it can work as soon as you install your refrigerator. If you do not fill the water tank, set the ice maker's On/Off feature to Off; otherwise, the ice maker's fill valve may make a loud chattering noise when it attempts to operate without water.

Ice production is controlled by the ice maker's On/Off feature on the control panel. Pressing the On/Off feature turns the ice maker on & off.



IMPORTANT

Turning off the ice maker simply disables ice making. You will still be able to dispense existing ice, and you will still be able to dispense water.

Ice maker/dispenser tips

- The following sounds are normal when the ice maker is operating:
 - Motor running
 - Ice dropping into ice bin
 - Water valve opening or closing
 - Running water

**CAUTION**

If the water supply to your refrigerator is softened, be sure the softener is properly maintained. Chemicals from a water softener can damage the ice maker.

Cleaning the ice maker

Clean the ice maker and ice bin at regular intervals, especially prior to vacation or moving.

1. Turn off the icemaker.
2. Remove the ice bin by pulling straight out.
3. Empty and carefully clean the ice bin with mild detergent. Do not use harsh or abrasive cleaners. Do not place in dishwasher. Rinse with clear water.
4. Allow the ice bin to dry completely before placing it back into the freezer.
5. Place ice bin back into position. Turn the ice maker on.

7. GENERAL INFORMATION

7.1 Cleaning your refrigerator



WARNING

BEFORE CLEANING: Turn the refrigerator off at the power point and unplug the cord to prevent any chance of electrocuting yourself.

Stainless Steel:

Your stainless steel refrigerator is manufactured from mark-resistant stainless steel. This stainless steel has a special advanced protective coating that eases the removal of marks such as fingerprints and water spots. To keep its appearance, clean it regularly with lukewarm soapy water and a soft cloth.



CAUTION

Never use stainless steel cleaners, abrasive pads or other cleaners that will scratch the surface. Damage to the appliance after delivery is not covered by your warranty.

Interior

Clean the inside of your refrigerator regularly with a soft cloth, unscented mild soap and lukewarm water. Thoroughly dry all surfaces and removable parts and avoid getting water on the controls. Replace removable parts, plug power cord in and switch the power on before returning the food.

Door seals

Always keep door seals clean by washing them with a mild detergent and warm water, followed by a thorough drying. Sticky food and drink can cause seals to stick to the cabinet and tear when you open the door.

Never use hot water, solvents, commercial kitchen cleaners, aerosol cleaners, metal polishes, caustic or abrasive cleaners, or scourers to clean your refrigerator. Many commercially available cleaning products and detergents contain solvents that will damage your refrigerator. Use only a soft cloth with an unscented mild soap and lukewarm water.



CAUTION

To clean a crisper simply wipe with a damp cloth and warm soapy water. Never immerse the cover in water, as this could affect the operation of the slide.

Switching off your refrigerator

If you switch off your refrigerator for an extended period, follow these steps to reduce the chances of mould.

1. Remove all food.
2. Remove the power plug from the power point.
3. Thoroughly clean and dry the Interior.
4. Ensure that all the doors are wedged open slightly for air circulation.

7.2 Air Filter

The air filter is located in the top center of the fresh food compartment.

Replacing your Air Filter

To ensure optimal filtering of refrigerator odors, you should change the air filter six months (The filter status light on the Touch Panel prompts you to replace the filter after six months)

1. Remove the air filter cover by squeezing the sides of the cover together and removing from liner
2. Remove the old filter and discard it.
3. Unpack the new filter and slide it into the housing. The open face must (carbon media) of the filter should be installed facing the air port (hole) in the multifold.
4. Replace the air filter cover by squeezing the sides and snapping it back into place.
5. Press and hold the "Reset Air Filter" button on the control panel for three seconds. When the LED turns off, the status has been reset.

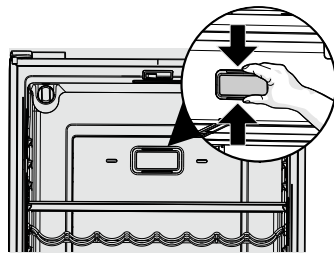

7.3 Ice and Water (selected models)

Clean the components of the ice maker/water dispenser regularly with a soft cloth, unscented mild soap and rinsing thoroughly with lukewarm water. For further information on the care and cleaning of your ice maker, ice dispenser or water dispenser refer to the section "Ice and Water Models"

7.4 Water Tank

The water tank is intended to be removed only for cleaning purposes, to fill the portable water only, the tank must be placed on the door and the funnel on the lid has to be used.

Clean the inside of the water tank regularly with a soft cloth and the filter use the soft brush to clean, unscented mild soap and rinse thoroughly with lukewarm water to completely remove any soap residue.

NOTE: When customer assembled tank to door To avoid water leaks ensure that tank nozzle fully engaged with housing socket.

8. FOOD STORAGE GUIDE

Category	Product	Recommended storage times for fresh foods*			Storage tips
		Refrigerator	TasteSeal Plus	Freezer	
Meat	Sausages and Mince	1-2 Days	3-5 Days	2-3 Months	Keep cold meat at the back of the refrigerator where it is coldest Plastic can cause meat to sweat if stored in refrigerator for more than a day.
	Chops and Steak	3-4 Days	5-7 Days	4-6 Months	
	Cold Meats	3-5 Days	5-7 Days	4-6 Months	Roast can take up to 48 hours to defrost properly, transfer frozen roast to the refrigerator 2 days before use.
	Roasts	3-5 Days	1 week	12 Months	
Poultry	Chicken	1-2 Days	5-7 Days	2 Months	If poultry takes on a smell or colour you are unsure about it is best to throw it out.
	Roast Chicken	3-5 Days	1 week	12 Months	
	Eggs	6 Weeks	Not Suitable	Not Suitable	Whole eggs are not suitable for freezing, slightly beaten eggs may be frozen for four months.
Seafood	Whole fish and filets	2-3 Days	5-7 Days	2 Months	Store in an airtight container or foil. Never freeze prawns in salty water as this will dehydrate the flesh.
	Lobster and Crab	1-2 Days	3-5 Days	2 Months	
	Prawns	1-2 Days	3-5 Days	2 Months	
Dairy	Milk	Until Expiry Date	Not Suitable	Not Suitable	If dairy takes on a smell or colour and you are unsure about it, it is best to throw it out
	Yoghurt	7- 10 Days	Not Suitable	Not Suitable	
	Hard Cheeses	2 Weeks – 2 Months	1-2 Months	2 Months (Grated)	Depending on the variety hard cheese can last from 2 weeks to 2 months.
	Soft Cheeses	1-2 Weeks	2-4 Weeks *	Not Suitable	* Texture may change depending of the type of soft cheese
	Butter	8 Weeks	3-4 Months	12 Months	
Fruit & Vegetables	Every fruit and vegetable has a different shelf life. Some stay fresh for a couple of days e.g. beans, others can last for a couple of months e.g. onions.		Not Suitable	8-12 Months When freezing chop and blanch in small portions.	Keep vegetables in the crisper and away from the air vents to avoid freezing. If you wash fruit and vegetables before storing them make sure they are dry or wrap in absorbent paper before storing in the refrigerator as this can make them susceptible to rotting. Try to keep fruit and vegetables separated as fruits that give off high levels of ethylene (the ripening agent) can prematurely ripen and spoil surrounding vegetables
Left Overs	Homemade meals	3-4 Days	Not Suitable	2-6 Months	Store in sealed container.
					Freeze meal in small portion sizes to limit wastage.

**IMPORTANT**

Please note, use this information as a guide only, actual storage times will vary depending on how you use your refrigerator, climatic conditions and the freshness of the food.

9. TROUBLESHOOTING

Appliance does not operate at desired temperature

In a modern frost free refrigerator / freezer, cold air is circulated around the various compartments through air vents using a high efficiency fan.

CONCERN	WHAT TO DO
Refrigerator is too warm	<ul style="list-style-type: none"> Adjust the refrigerator to a colder setting Ensure food is allowed to cool before placing inside the refrigerator. Ensure the appliance is set up as per instructions Ensure that contents are not obstructing the cooling vents. Ensure the door is not held open or is being opened too frequently.
Freezer is too warm	<ul style="list-style-type: none"> Adjust temperature to a colder setting. Ensure food is allowed to cool before placing inside the freezer. Ensure the appliance is set up as per instructions Ensure that contents are not obstructing the cooling vents. Ensure the door is not held open or is being opened too frequently.
Food is freezing in the refrigerator	<ul style="list-style-type: none"> Adjust temperature to a warmer setting. Ensure that fruit and vegetables are stored in the crisper. Items with a high water content should not be placed near the cooling vents.
Unable to change temperature settings	<ul style="list-style-type: none"> Refer to sections "temperature control" and "about the user interface". Ensure that user interface is in "awake" mode before trying to adjust temperature settings.

Appliance noise

Your new refrigerator may make sounds that your old one didn't make. Because the sounds are new to you, you might be concerned about them. Most of the new sounds are normal. Hard surfaces, like the floor, walls and cabinets, can make the sounds seem louder than they actually are. The following describes the kinds of sounds and what may be making them.

CONCERN	WHAT TO DO
Motor noise (compressor)	<p>Nothing. This is normal as your new refrigerator uses a high-speed compressor which switches on and off during operation.</p> <p>Note that the compressor noise may seem louder at the start of the on cycle.</p>
Motor noise (compressor);	<p>These refrigerators are fitted with a variable speed compressor and fan. At start up and on warm days they run at a higher speed to provide additional cooling. When less cooling is required the compressor and fan will run at a lower speed. As a result it is normal for sound levels to change depending on operating conditions.</p>
A clicking noise heard just before the compressor starts.	<p>Nothing. This is normal as your new refrigerator has an automatic switching action of the temperature control, turning the compressor on and off.</p>

CONCERN	WHAT TO DO
Occasional gurgling, similar to water boiling.	Nothing. As each cycle ends, you may hear a gurgling sound due to the refrigerant flowing in your refrigerator system. Nothing, this is normal as your new refrigerator uses high efficiency fans to circulate air. Fan speed and noise may increase during periods of heavy usage or hot weather.
Rattling and other noises.	<ul style="list-style-type: none"> • Ensure that the cabinet is level and stable, refer to Installation Instructions • Check the surrounds of the appliance to ensure there is nothing touching or placed on top of the appliance. • Ensure that contents of the appliance are not placed in such a way that they are vibrating (such as bottles).

Crisper Operation

CONCERN	WHAT TO DO
Excess moisture build up in crisper It is normal for there to be some moisture and humidity in the crisper bin.	<ul style="list-style-type: none"> • Ensure that the crisper is not over packed. • Adjust crisper humidity slides.
Crisper bin can not be removed	<ul style="list-style-type: none"> • If crisper bin interferes with the door bins, remove door bins before removing crisper. • Position cabinet so that the door can be fully opened.
Freezing items in the crisper	<ul style="list-style-type: none"> • Adjust temperature to a warmer setting.

Refrigerator operation

CONCERN	WHAT TO DO
Appliance will not run It is normal for the freezer fan not to operate during the automatic defrost cycle, or for a short time after the appliance is switched on.	<ul style="list-style-type: none"> • Ensure that the cord is plugged into a live power outlet and outlet is switched on. • Ensure that the household circuit breaker has not tripped or that the fuse has not blown. • The appliance maybe in defrost mode, check again in half an hour.
Compressor motor seems to run too long At normal room temperatures, expect your motor to run about 40% to 80% of the time. Under warmer conditions, expect it to run more often.	<ul style="list-style-type: none"> • Ensure that the doors are not held open. • Check that large amounts of warm food have not just been placed inside the appliance. • Note that the appliance will run more than normal just after you install it or when adjusting the temperature setting changes.

CONCERN	WHAT TO DO
<p>Compressor motor seems to run too long . These appliances use a variable speed compressor, which by design can run for long periods of time, this is normal</p>	<ul style="list-style-type: none"> • The variable speed compressor and fan that at start up and on warm days, runs at high speeds to provide additional cooling. When less cooling is required the compressor and fan will run at a lower speed, but still may not switch off. This is normal. • It is possible that the only time the compressor and fan will stop is when the refrigerator is defrosting which is approximately once per day.
<p>The exterior of the appliance is warm or hot to touch</p> <p>This is normal because the appliance transfers heat from the inside out through the outer panels and the divider between the doors.</p>	<ul style="list-style-type: none"> • Ensure the appliance has the external clearances recommended in the section “Installing your new appliance”. • The exterior of the cabinet will be much warmer on warmer days it may even feel hot to touch, as the appliance is working harder.
<p>User interface will not respond</p> <p>To ensure settings are not accidentally changed the user interface will go into sleep mode when not in use. Press any button to wake user interface</p>	<ul style="list-style-type: none"> • Check that the user interface is in awake mode, refer to section “About the user interface”. • Check that the user interface is not locked, refer to section “About the user interface”. • If the user interface is frozen turn the appliance off for five minutes for the memory to clear, then turn back on.
<p>Alarms Sounding</p>	<ul style="list-style-type: none"> • Check that all doors are fully closed. • Ensure that the over temperature alarm is not being activated by hot food placed in the freezer. • Check if the drinks timer has ended, refer control instructions.
<p>Frost build up</p>	<ul style="list-style-type: none"> • Check that all doors are fully closed. • Ensure that the doors are not opened too often. • Ensure that the return air vents are not blocked with packaging. • Ensure the seals are clean and not obstructed.
<p>Odours</p>	<ul style="list-style-type: none"> • The interior may need cleaning, refer to cleaning guide. • Ensure that food is stored correctly as some food, containers and wrapping can produce odours. • Check appliance for old or unusual food.
<p>Lights not working</p> <p>The LED lighting is esigned to turn on gradually. The LED lighting is designed to dim automatically if the door is left opened for more than 5 minutes and turn off completely if the door is open for more than 7 minutes. Closing the door will reset the timer.</p>	<ul style="list-style-type: none"> • Ensure that the cord is plugged into a live power outlet and outlet is switched on. • Ensure that the household circuit breaker has not tripped or that the fuse has not blown. • Check the appliance features section to determine lighting configuration for your model.

Door operation

CONCERN	WHAT TO DO
Freezer door pops open.	<ul style="list-style-type: none"> • This is normal and should re-close. This happens when the refrigerator door is closed too quickly. • If the freezer door stays open, it indicates that the appliance needs to be tilted backwards a little further. Refer to section "Installing your new appliance".
Self close not working.	<ul style="list-style-type: none"> • Check if your appliance has self closing hinges as not all models do. • It indicates that the appliance needs to be tilted backwards a little further. Refer to section "Installing your new appliance".
Door not sealing properly	<ul style="list-style-type: none"> • Ensure there is nothing that is preventing the door from closing such as appliance contents or items placed near the appliance. • Ensure that the crisper/freezer bin is closed completely. Refit if required as referred to in the section "Using your refrigerator". • Ensure the appliance is set up as per recommendations.
Door difficult to open and close	<ul style="list-style-type: none"> • If the door is difficult to open just after you have closed it this is due to the pressure equalising, the door will open normally after a few minutes.

If you still require service

If you have a problem, and the problem persists after you have made the checks mentioned, contact your nearest Electrolux approved Service Centre or the dealer you bought the refrigerator from. Be ready to quote the model number, the 9-digit PNC and 8-digit serial number, which is stated on the label inside the refrigerator compartment.

10. NOISES

Appliance noise

Your new refrigerator may make sounds that your old one didn't make. Because the sounds are new to you, you might be concerned about them. Most of the new sounds are normal. Hard surfaces, like the floor, walls and cabinets, can make the sounds seem louder than they actually are. The following describes the kinds of sounds and what may be making them.

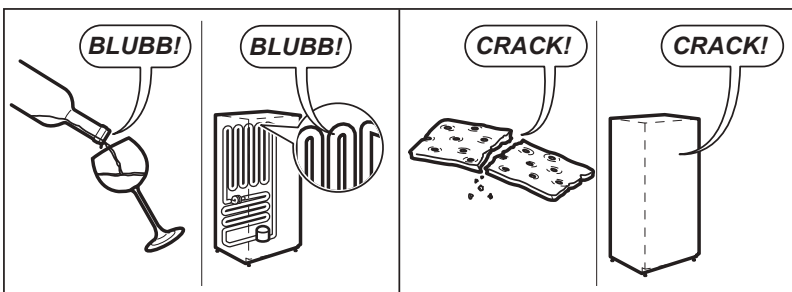
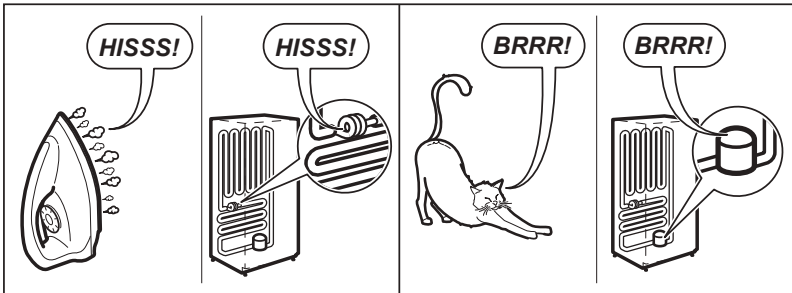
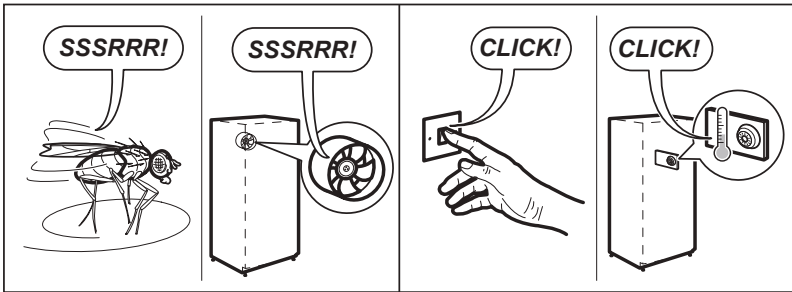
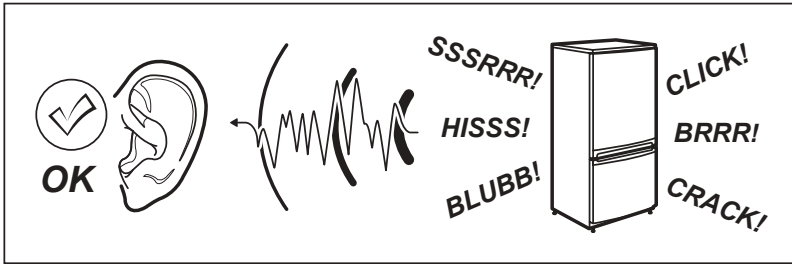

目錄

1. 安全資訊.....	3
2. 設備說明.....	5
3. 安裝新設備.....	7
4. 溫度控制.....	11
5. 存儲功能.....	17
6. 自動冰水機.....	20
7. 一般資訊.....	22
8. 食物存放指南.....	24
9. 故障排查.....	25
10. 噪聲.....	29

我們一心為您

感謝您選擇 Electrolux。Electrolux 雪櫃讓您的生活變得更加簡單舒適，使用多年後依然保持出色效能。請抽出幾分鐘時間仔細閱讀本手冊，以獲得這台全新 Electrolux 設備的最佳使用體驗。

敬請瀏覽產品網站：



獲取使用建議或服務資訊：
www.electrolux.com





註冊產品以獲得升級服務：
www.electrolux.com/support/register-warranty

客戶關懷與服務

務必使用原廠備件。

聯絡我們的授權服務中心時，請確保提供以下資料：型號、PNC 碼、序號。
此資訊位於產品銘牌上。

-  警告/安全注意事項。
-  一般資訊與貼士。
-  環境資訊。

如有變更，恕不另行通知。

1. 安全資訊

註：安裝或使用雪櫃之前，務必仔細閱讀該警告資訊。如需協助，請聯絡客戶服務中心。若忽略本手冊中的說明或其他任何安全警告，由此造成的後果製造商概不負責。

警告

- 請務必確保電氣插座正確接地。若無法確定，請諮詢符合資質的電氣檢修員。
- 切勿在設備的食物儲藏室內使用電氣設備，除非製造商推薦使用。
- 清潔或移動本設備之前，請先拔下電源插頭以防止觸電。
- 拔下電源插頭時切勿拖拉電源線，此舉可能會損壞電源插頭。緊緊抓住插頭並保持水平拔出。
- 如電源線已損壞，必須由製造商、服務代理商或其他符合資質的人士予以更換，以免造成危險。
- 禁止使用蒸汽清潔器。當帶電元件接觸到冷凝的蒸汽時，可能會形成短路或造成觸電。
- 禁止儲藏易爆物質，例如將氣溶膠罐連同易燃推進劑一起存放在本設備中。若加壓氣溶膠容器帶有「易燃」字樣及/或小火焰符號，禁止將其存放在任何雪櫃或冷凍室內。否則可能引致爆炸。
- 禁止破壞雪櫃電路。
- 此設備包含由可燃發泡劑形成的絕緣層。請小心棄置本設備以免造成危險。
- 若需要棄置本雪櫃，請聯絡當地相關機構以獲取正確的棄置方法。
- 棄置廢棄的雪櫃時及冷凍室時，請拆除所有雪櫃門。若兒童被困於雪櫃內，可能會窒息。
- 放置雪櫃時，確保電源線未扭結或受損。
- 禁止在本設備後方放置多個可攜式插座或可攜式電源。



警告 R600a 雪櫃警告



本設備包含易燃 R600a 冷凍劑。請小心安裝、處理、維修及棄置本設備以免造成危險。

- 確保在運輸與安裝期間冷凍劑管路完好無損。
- 冷凍劑洩漏可能導致眼部受傷或起火。
- 本機必須安裝在每 8g 冷凍劑至少能夠分配到 1m³ 的房間內。設備的冷凍劑總量標註於設備內部的銘牌上。
- 若不確定冷凍劑總量，可查閱雪櫃內的銘牌。
- 若由非授權維修人員維修本設備，可能會造成危險。澳洲昆士蘭規定，授權維修人員必須持有碳氫冷凍劑的氣體作業許可證，方可進行拆除蓋板等維修工作。
- 保持設備外殼或內置結構中的通風口暢通無阻。
- 禁止使用非製造商推薦的機械裝置或其他方式加速除霜過程。

一般警告

仔細閱讀下文警告以避免損壞或人員受傷。安全使用雪櫃至關重要。使用雪櫃前請務必查閱這些安全注意要點。

- 本設備必須使用專屬電源插座。
- 放置雪櫃時必須確保可接觸到插頭。
- 請務必確保電源插座正確接地。若無法確定，請諮詢符合資質的電氣檢修員。
- 禁止對本設備使用延長線或轉接插頭。
- 如電源線已損壞，必須由製造商、服務代理商或其他符合資質的人士予以更換，以免造成危險。
- 清潔前及更換燈泡（如安裝）前請先拔下插頭以免觸電。
- 拔下電源插頭時切勿抽拉電源線，此舉可能會損壞電源插頭。緊緊抓住插頭並保持水平拔出。
- 避免將雪櫃放置在溫度過低處。室內環境溫度應高於 10°C。
- 確保雪櫃周圍乾燥，避免將雪櫃放置在潮濕處。
- 禁止將雪櫃放置在結霜或無保護的區域，例如車庫或陽台。
- 禁止將雪櫃插頭插入帶計時器的電源。
- 禁止將雪櫃置於陽光下，靠近火爐、明火或熱源。
- 禁止將雪櫃置於不平坦的表面。
- 禁止在本設備上方或下方存放易燃材質，例如氣溶膠。
- 禁止儲藏易爆物質，例如將氣溶膠罐連同易燃推進劑一起存放在本設備中。
- 禁止將碳酸飲料置於冷凍室內。
- 禁止擅自嘗試維修，僅由符合資質或授權之專業維修人士進行維修。

- 禁止使用電加熱器或吹風機為冷凍室除霜，此舉可能會造成觸電
- 運輸或安裝雪櫃時，需小心以確保製冷電路完好無損。
- 正確安裝後，雪櫃應：
 - 後方及兩側留有足夠空間以確保空氣流通。
 - 與周圍的櫥櫃垂直對齊。
 - 雪櫃門處於部分打開位置時能夠自動關閉。
- 本雪櫃不適合身體殘障、感官或精神功能減退或缺乏相關經驗和知識的人員（包括兒童）使用，除非有負責其安全的人員對其使用本機給予監督或指導。
- 應監督兒童不要將本雪櫃當做玩具。

註：安裝或使用雪櫃之前，務必仔細閱讀該警告資訊。如需協助，請聯絡客戶服務部門。若忽略本手冊中的說明或其他任何安全警告，由此造成的後果製造商概不負責。



環境資訊

本雪櫃旨在用於家庭環境及類似應用場景，例如：

- 商店、辦公室或其他工作環境的廚房區域；
- 農舍及酒店、汽車旅館及其他居民場所；
- 餐飲及住宿場所；
- 餐飲及類似的非零售應用場景；

2. 設備說明

2.1 可製冰水的 QUATTRO 法式櫃門雪櫃功能

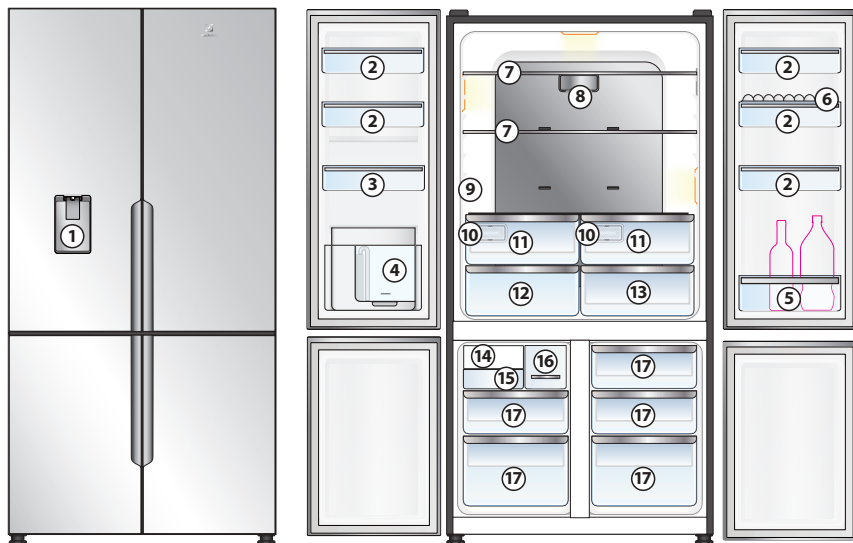

EQE5660 圖示說明

1	飲水機觸發器	10	抗氧化過濾器
2	櫃門儲物盒*	11	TasteLockAuto 抽屜
3	櫃門小號儲物盒*	12	TasteSealPlus 抽屜
4	水箱	13	熟食抽屜
5	瓶架	14	自動製冰機
6	雞蛋儲存格	15	小型冰盒
7	玻璃架	16	冰盒架冷凍室
8	空氣過濾器	17	冷凍室抽屜
9	UI 控制面板 (位於左壁)		

註：

* 櫃門儲物盒 (3) 略小於櫃門儲物盒 (2)，必須根據上圖所示位置安裝。

2.2 QUATTRO 法式櫃門雪櫃功能

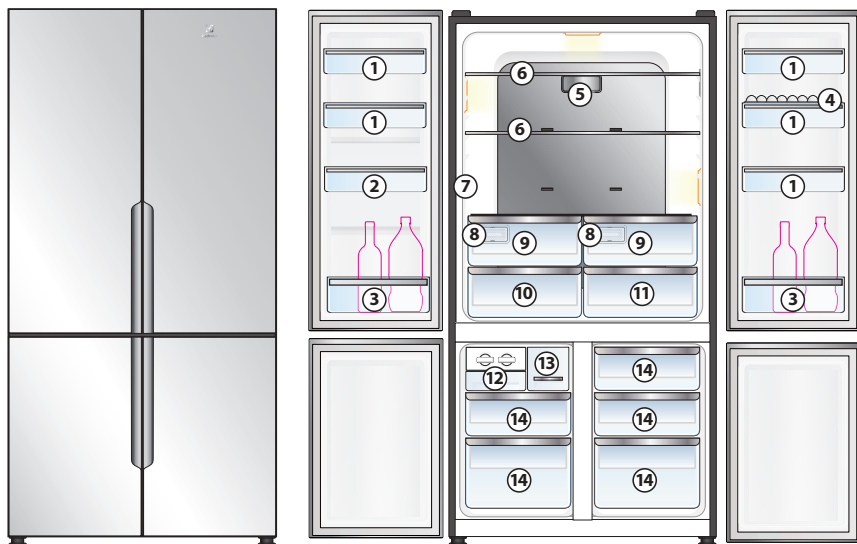

EGES600 圖示說明

- | | | | |
|---|----------------|----|------------------|
| 1 | 櫃門儲物盒* | 8 | 抗氧化過濾器 |
| 2 | 櫃門小號儲物盒* | 9 | TasteLockAuto 抽屜 |
| 3 | 瓶架 | 10 | TasteSealPlus 抽屜 |
| 4 | 雞蛋儲存格 | 11 | 熟食抽屜 |
| 5 | 空氣過濾器 | 12 | 旋轉出冰式冰盒 |
| 6 | 玻璃架 | 13 | 冰盒架冷凍室 |
| 7 | UI 控制面板 (位於左壁) | 14 | 冷凍室抽屜 |

註：

* 櫃門儲物盒 (2) 略小於櫃門儲物盒 (1)，必須根據上圖所示位置安裝。

3. 安裝新設備

拆除包裝



保護環境

大部分包裝材料均可回收。請將該等材料放入您當地的回收站或將它們放入適當的收集容器中。

重要提示 — 檢查是否有任何損壞或劃痕。如發現雪櫃受損或有劃痕，必須在 7 日內提交報告方能就製造商保固範圍內的損壞/劃痕提出索償。這不會影響您的法定權利。

按照「清潔」部分的說明徹底清潔雪櫃，擦掉在運輸期間積聚的任何灰塵。

放置雪櫃



注意

本產品附近不適合放置自動氣霧劑系統（例如殺蟲裝置），因為噴霧可能會對本雪櫃的外部塑料造成長期損壞。

切勿將雪櫃放置於過冷或無保護的地方，例如車庫或陽台。環境溫度應高於 10°C。

將雪櫃放置於乾燥環境下，避免將雪櫃放置在潮濕處。

確保雪櫃位於平整表面。

安裝雪櫃

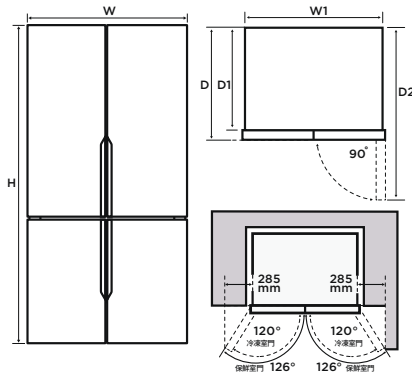

產品尺寸

總寬度 (W)	mm	896
總深度 (D)	mm	726
最大高度 (H)	mm	1795
櫃體寬度 (W1)	mm	890
櫃體深度 (D1)	mm	640
櫃門打開 90° 時的深度 (D2)	mm	1104

當放置在角落區域時，鉸鏈側的間距要求為至少 285mm，這是雪櫃門能打開到足以取出儲物盒及層架的距離。

最佳美學安裝選項：

距離廚櫃最小邊距

雪櫃必須高出櫥櫃 10mm。

最小櫥櫃開口（寬x深x高）：

900mm x 649mm x 1800mm

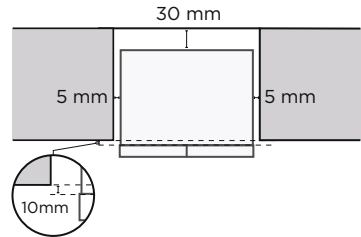

櫃體正面與櫥櫃保持齊平

要使雪櫃門突出於櫥櫃，櫃體任一側的側隙必須保持在 25mm。

最小櫥櫃開口（寬x深x高）：

940mm x 659mm x 1800mm

註：配備分隔器提供輔助

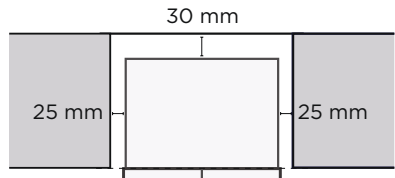

雪櫃門與櫥櫃齊平

要使雪櫃門與櫥櫃齊平，櫃體任一側的側隙必須保持在 90mm。

最小櫥櫃開口（寬x深x高）：

1070mm x 741mm x 1800mm

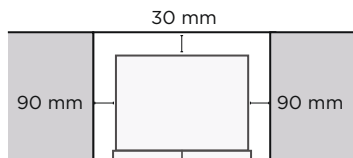

註：頂部空隙 5 mm。

1. 將雪櫃滾動至放置位。

滾輪的設計僅允許向前或向後移動。它們並不是腳輪。橫向移動雪櫃可能會損壞地面和滾輪。在移動雪櫃之前確保高度調節螺母和穩定支腳完全脫離地面。

2. 向下轉動櫃門鉸鏈下方的大號高度調節螺母，直至雪櫃向後傾斜 10mm（見圖）。

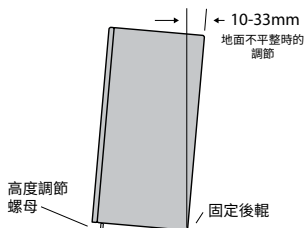

3. 向下擰動把手側的大號高度調節螺母，直至雪櫃平穩落地。如果難以將螺母或高度調節支腳向下擰動，讓另一個人將雪櫃向後傾斜，這樣便於您更好地操作。

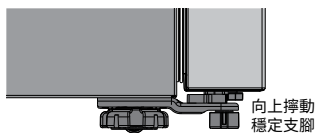

4. 檢查雪櫃與周圍櫥櫃的對齊情況，看是否保持齊平。可以根據第 2 步和第 3 步進行調平。

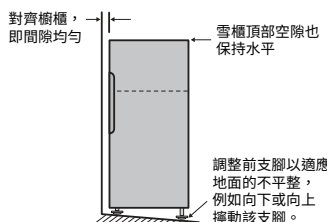

5. 如果發現雪櫃在角落之間滾動，則表示地面不平整。找一塊塑膠或硬板等，將其包裹在滾輪下方並保持牢固。
6. 現在，可能需要重複第 3、4、5 步以進行微調。
7. 當本機最終放置到位後，需要確保其穩固。將門鉸鏈下方的穩定腳向下纏繞到地板上，直至其剛好與地板接觸。抬起雪櫃的前部以減輕穩定支腳的重量，然後旋轉半圈，以確保它們與地面牢固接觸。回向擰動大號高度調節螺母，以確保所有重量現在都在前穩定腳上。回向擰動大號高度調節螺母，以確保所有重量現在都在前穩定腳上。

正視圖

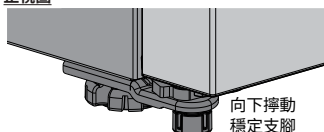

8. 對手柄側的穩定支腳重複第 7 步。每當您需要移動設備時，請務必將支腳向後捲起，以便設備可以自由滾動，並確保在重新安裝時將其重置。
9. 將雪櫃直接插入專用電源插座，切勿使用雙適配器。如果需要滾動雪櫃才能接觸到插頭，請務必先抬起穩定腳。
10. 在將任何食物放入雪櫃之前，建議您先將其開啟 2 或 3 小時，以檢查其運行是否正常。

櫃門打開

雪櫃的放置位置應便於您將食物取出並放置於櫃檯上。為能夠最大程度地利用雪櫃抽屜和冷凍籃，您應考慮將雪櫃放置於能夠完全打開二者的位置。



警告 LED 照明燈

本雪櫃安裝了超長壽命 LED 照明燈。如果 LED 燈出現故障，則 LED 燈應由服務代理商進行維修，以避免出現危險。請參閱保固頁面以瞭解詳情。

櫃體調平與雪櫃門對齊 (如有必要)

- 櫃體的所有四個角落都必須穩固地落於地面。
- 前部應略微抬高，以確保櫃門能夠正確關閉和密封。
- 櫃門應彼此對齊並保持水平。

抬起或降低可調節前滾輪即可滿足上述大部分條件。

使用前滾輪調平櫃體：

1. 降低防傾支腳，直至它們都接觸到地板。使用鉗子進行調整。
 - 升高：順時針轉動支腳。
 - 降低：逆時針轉動支腳。

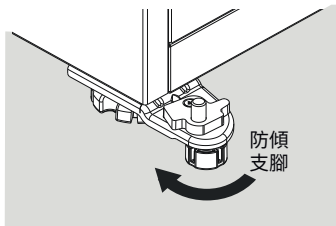

2. 確保兩扇櫃門均未卡住，封條都接觸到櫃體的所有四個側邊，且櫃體保持穩定。

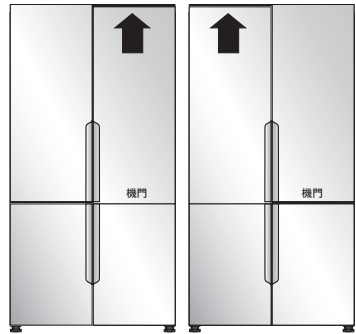

鑷狀門楞

調節鑷狀門楞，確保鑷狀門楞折疊並垂直於保鮮櫃門，從而正確連接門楞導軌。如果門楞導軌不在正確位置，將導致櫃門無法完全關閉。

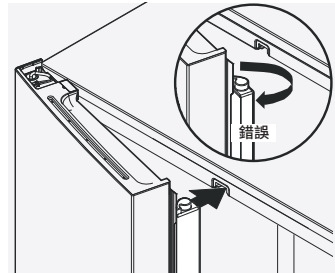

安裝空氣過濾器

1. 拆除空氣過濾器蓋。
2. 拆除空氣過濾器上的塑膠袋，將空氣過濾器放入空氣過濾器蓋內。
3. 然後將空氣過濾器蓋與過濾器一起安裝在多流道上。

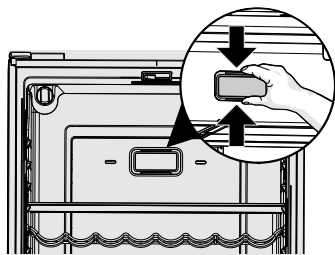

NutriPlus™ (抗氧化過濾器)

安裝過濾器濾芯

過濾器位於保鮮格內。為充分享用 NutriPlus™ 的優勢，必須在開啟雪櫃後再安裝它。請遵守以下操作說明完成安裝。

1. 拆除塑膠膜。
2. 將包裝袋插入保鮮格側面的支架中。

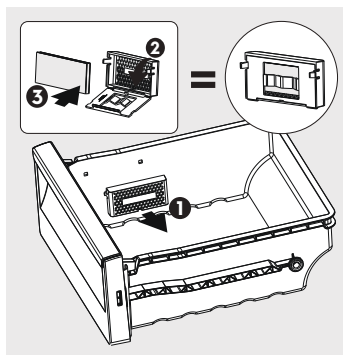

4. 溫度控制

下頁介紹使用者介面的各項功能，以幫助您最大限度地利用新雪櫃。



重要

註：設定溫度時，為整個雪櫃設定一個平均溫度。確保只進行小幅調整並等待至少 24 小時，看看新溫度是否符合您的使用喜好。

檢查雪糕的柔軟度是判斷冷凍室溫度是否正確的一個很好的辦法，而檢查雪櫃內水的溫度是判斷食物儲藏室溫度的一個好辦法。

每個儲藏室的溫度可能不同，具體取決於您存放的食物量以及放置食物的位置。

室溫的變化可能也會影響雪櫃內部的實際溫度。

4.1 使用者界面的功能

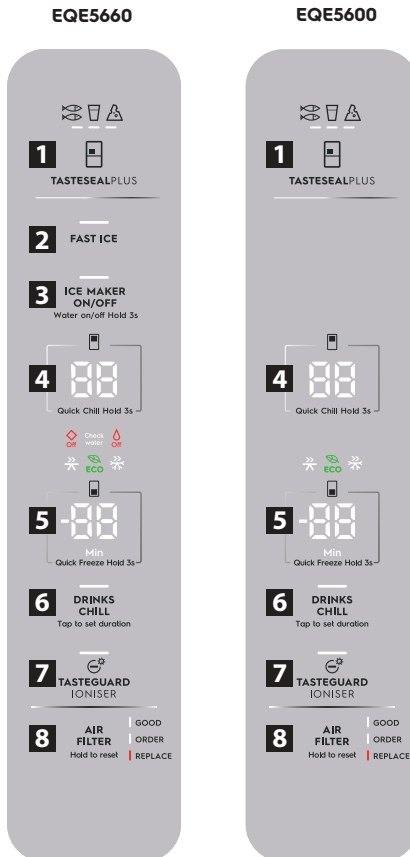

1 TasteSeal Plus 控制

2 快速製冰按鈕

3 自動製冰機控制



4 雪櫃溫度控制





5 冷凍室溫度控制

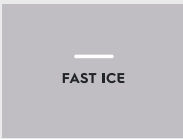

6 飲品冷卻按鈕

7 保鮮離子發生器

8 空氣過濾器重設按鈕

功能	圖示	操作 (視乎型號而定)
<p>1 TasteSeal Plus 控制</p>	<p>肉類與魚類</p>  <p>冷飲模式</p>  <p>熟食小食模式</p> 	<p>輕觸 TasteSealPlus 按鈕，啟用下一個模式。下一個模式的 LED 燈亮起。</p> <p>TasteSeal plus 設有 3 種溫度模式：</p> <p>-2°C 肉類與魚類</p> <p>-0°C 冷飲</p> <p>3°C 熟食小食</p>
<p>2 快速製冰按鈕</p>		<p>輕觸快速製冰按鈕。</p> <p>開啟快速製冰時，快速製冰指示燈亮起。</p> <p>關閉快速製冰時，快速製冰指示燈熄滅。</p> <p>開啟快速製冰時，壓縮機將持續運行 24 小時。雪櫃和 TasteSealPlus 冷藏室繼續在設定溫度下運行。</p> <p>達到以下任一條件後，快速製冰功能自動關閉：</p> <ul style="list-style-type: none"> - 經過 24 小時 - 冷凍室溫度調節至 -23°C <p>註：</p> <p>*急凍和快速製冰功能不可同時啟用。如果開啟急凍，則快速製冰功能將不可用。</p> <p>**當冰盒裝滿後，快速製冰功能不會停止。自動製冰機將停止運作，但快速製冰 12 小時計時器將繼續倒計時。</p> <p>每當冰盒內的水位下降時，自動製冰機將繼續製冰，同時快速製冰功能將保持開啟。</p>

功能	圖示	操作 (視乎型號而定)
<p>3 自動製冰機控制</p>	 <p>缺少冰塊警報指示燈</p>  <p>缺水警報指示燈</p> 	<p>輕觸製冰機開/關按鈕。</p> <p>當開啟製冰機時，按鈕 LED 亮起。</p> <p>當關閉製冰機時，按鈕 LED 熄滅。</p> <p>缺少冰塊警報指示燈亮起。</p> <p>按住製冰機開/關按鈕保持 3 秒。</p> <p>開啟此開關後，當按下飲水機接水器時將開始進水。</p> <p>關閉此開關後，當按下飲水機接水器時將不會進水。</p>
<p>4 雪櫃溫度控制</p>		<p>輕觸螢幕以在雪櫃的預設溫度範圍內切換。</p> <p>最高 7°C</p> <p>最低 1°C</p> <p>預設 4°C</p>
<p>5 冷凍室溫度控制</p>		<p>輕觸螢幕以在冷凍室的預設溫度範圍內切換</p> <p>最高 -14°C</p> <p>最低 -23°C</p> <p>預設 -18°C</p>
<p>6 飲品冷卻</p>	<p>飲品冷卻定時器指示燈</p> 	<p>飲品冷卻定時器用於快速冷卻冷凍室內的飲品，並在結束時提醒使用者。</p> <p>輕觸飲品冷卻按鈕，冷凍室螢幕將顯示 20，「Min (最低)」和飲品冷卻 LED 燈亮起。</p> <p>定時器選項從 20 分鐘開始，使用者可以按 5 分鐘的間隔增加時間，最長 45 分鐘。啟動後，定時器將逐分鐘顯示倒計時。</p> <p>註：</p> <p>定時器倒計時過程中，不能調整定時器時長。使用者需要停用飲品冷卻並再次啟用飲品冷卻功能以設定新的定時器。</p>

功能	圖示	操作 (視乎型號而定)
7 保鮮離子發生器		<p>輕觸離子發生器按鈕。</p> <p>當開啟離子發生器時，離子發生器按鈕 LED 亮起。</p> <p>當關閉離子發生器時，離子發生器按鈕 LED 熄滅。</p> <p>離子發生器是一種旨在減少雪櫃內細菌水平的裝置，有助於延長食物保存時間。</p> <p>它在運行時會產生臭氧，將臭氧量保持在安全限值 (0.1ppm) 內非常重要，因此離子發生器的運行將遵守一個簡單的開/關邏輯。</p> <p>離子發生器不會影響 ECO 狀態。當離子發生器運作時，ECO 指示燈將保持亮起。</p> <p>停用離子發生器：</p> <ul style="list-style-type: none"> - 輕觸離子發生器按鈕以關閉 - 設定為「假日」模式。 <p>注意</p> <ul style="list-style-type: none"> - 離子發生器在櫃門打開的情況下將停止運作，當櫃門關閉後會自動重啟。 - 離子發生器在除霜期間將停止運作，除霜結束後會自動重啟。
8 空氣過濾器警報和重設		<p>「GOOD」(良好) LED 燈亮起時，表示過濾器已使用了 0-4 個月。</p> <p>「ORDER」(訂購) LED 燈亮起時，表示過濾器已使用了 5 個月，提醒使用者需要訂購新的濾水器。</p> <p>「REPLACE」(更換) LED 燈亮起時，表示過濾器已使用了 6 個月。</p> <p>按住空氣過濾器 3 秒即可重設。狀態將重設為 GOOD (良好)。</p>
急速冷卻控制	 <p>急速冷卻控制指示燈</p>	<p>按住雪櫃數字 3 秒鐘。</p> <p>輕觸雪櫃數字以調節溫度。</p> <p>當開啟急速冷卻時，急速冷卻指示燈亮起。</p> <p>當關閉急速冷卻時，急速冷卻指示燈熄滅。</p> <p>當您從商店購回大量食物並準備放入冷藏室或想要快速冷卻飲料時，請使用急速冷卻功能。開啟急速冷卻功能後，冷空氣循環進入雪櫃，將溫度暫時降至 1°C，並持續 6 小時，冷凍室將在設定溫度下繼續運行。</p> <p>達到以下任一條件後，急速冷卻功能自動關閉：</p> <ul style="list-style-type: none"> - 經過 6 小時後 - 雪櫃溫度被重新調節

功能	圖示	操作 (視乎型號而定)
急凍控制	 <p>急凍控制</p> 	<p>按住冷凍室數字 3 秒鐘。 輕觸冷凍室數字以調節溫度。</p> <p>當開啟急凍時， 急凍指示燈亮起。</p> <p>當關閉急凍時， 急凍指示燈熄滅。</p> <p>當您從商店購回大量食物並準備放入冷凍室，或想要加速冷凍時，請使用急凍功能。開啟急凍時，壓縮機將持續運行 6 小時。雪櫃冷藏室繼續在設定溫度下運行。</p> <p>達到以下任一條件後，急凍功能自動關閉：</p> <ul style="list-style-type: none"> - 經過 6 小時後 - 冷凍室溫度調節至 -23°C <p>註：急凍和快速製冰功能不可同時啟用。如果開啟快速製冰功能，則不能啟用急凍。</p>

4.2 警告與警報

櫃門警報

當任何櫃門開啟超過 2 分鐘時，將響起警報，所有 LED 亮起。

- 關閉櫃門後，或按下控制面板上的任意鍵以重設倒計時，警報即停止。

高溫警告

如出現溫度過高，每 10 秒鐘將發出一聲警報，直至警報被確認。

按下控制面板上的任意鍵可停止警報。

出現高溫時，相應的雪櫃室顯示螢幕上將出現閃爍的「HI」。



冷藏室顯示螢幕上的
高溫指示燈



冷凍室顯示螢幕上的
高溫指示燈

ECO 指示燈

當冷藏室和冷凍室設定在某個溫度範圍內時，Eco 模式指示燈將自動亮起至 100%。

冷藏室溫度範圍：4°C 至 7°C

冷凍室溫度範圍：-18°C 至 -14°C

選擇任何模式：急凍、急速冷卻、快速製冰或飲品冷卻，將停用 Eco 模式，Eco 圖示將熄滅。



空氣過濾器警報和重設

空氣過濾器警告使用者必須盡快更換空氣過濾器。

自從上一次重設過濾器起，經過 6 個月後，LED 「Replace」（更換）將自動亮起。

註：

- 使用者可以在警報未出現時重設過濾器。重設後將播放 tone_Confirm 音。
- 在睡眠模式期間，LED 空氣過濾器保持可見，櫃門關閉時除外。

檢查水位警報（僅限 EQE5660 型號）

當水箱空箱時，製冰機會感應到缺少溫水進入，隨之會關閉製冰機。

Check
water

此時會觸發顯示「Check water（檢查水位）警報」。這是為了提醒使用者，由於缺水製冰機已關閉。

開啟製冰機即可解除警報。如果再次偵測到缺水，製冰機將再次關閉，檢查水位警報再次開啟。

錯誤代碼

冷藏室與冷凍室顯示螢幕均會透過代碼提示問題。

當數字顯示器上顯示錯誤代碼時，表示裝置需要注意維修。

冷藏室顯示螢幕上顯示「Er」



冷凍室顯示螢幕上顯示的各種錯誤代碼



錯誤代碼表	
通訊錯誤	CE
FZ 腔室 NTC	T1
FZ 蒸發器 NTC	T2
FF 腔室 NTC	T3
第三腔室 NTC	T5
FZ 製冰機 NTC	T8

5. 存儲功能

玻璃架

要拆除層架，輕輕向前拉，直到層架脫離層架軌道。
放回層架時，確保後方沒有任何妨礙移動的異物。
輕輕地推入層架，直至其回到原位。

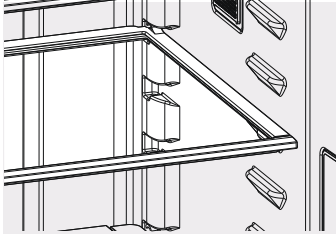

注意

請小心操作鋼化玻璃架，以免造成人員受傷或財產損壞。如果遭到刻畫、刮擦，或暴露於急速的溫度變化下，擱架可能會突然破裂。清潔之前，首先讓玻璃架在室溫下穩定。請勿放入洗碗機清洗。

抽屜

本產品含有多個儲藏抽屜。

保鮮格（帶自動濕度控制）

保鮮格抽屜用於存放水果、蔬菜及其他新鮮食材。每一個保鮮格的背面均帶有自動控濕功能（帶有可替換薄膜），位於濕度控制蓋下方。

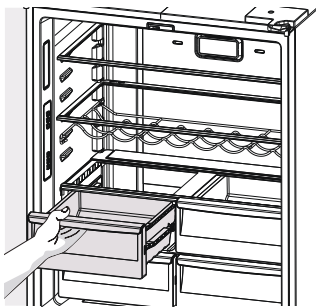

打開保鮮格抽屜

拆除自動控濕薄膜：

1. 找到濕度控制蓋背面。
2. 拉起蓋板。
3. 將蓋子向機櫃背面拉出並取下。
4. 更換薄膜。
5. 反向操作上述步驟以重新安裝蓋板。

對每個保鮮格重複此操作。

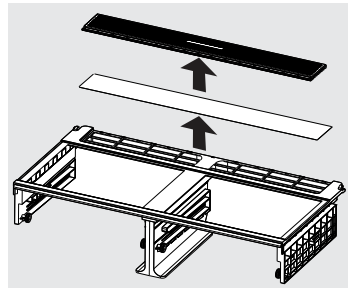

拆除自動控濕薄膜



重要

除非損壞或破損，否則無需更換自動保濕膜。如果膜變髒，可以用肥皂和水清洗。放回保鮮格抽屜之前，確保保濕膜已乾燥。當需要更換自動保濕膜時，請聯絡我們的服務提供商。

拆除保鮮格進行清潔：

1. 拉出抽屜，直到拉不動為止。
2. 微微抬起前端，抽出抽屜。

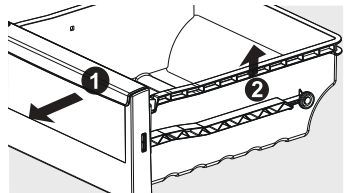

拆除保鮮格

雪櫃門 儲存盒

保鮮室的櫃門採用組合式儲存盒。所有這些儲存盒均可拆除，便於清潔。您亦可按自身需要調整儲存盒。

櫃門儲物盒適合存放罐子、瓶子、罐頭和大型飲料容器。這些儲物盒亦便於取用常用物品。

拆除櫃門儲物盒：

1. 從掛耳上提起並解鎖以卸下。
2. 安裝時，向上抬起並向下推儲物盒直至掛耳鎖緊到位。

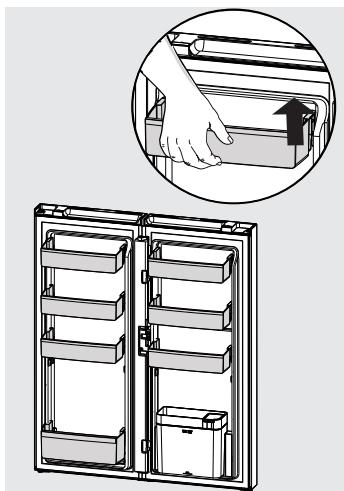

拆除櫃門儲物盒

水箱



注意

拆除前，必須清空水箱內的水。

要拆除水箱和可拆卸的可清潔零件，請執行以下步驟：

1. 抬起水箱，直至鎖緊器鬆開。
2. 向前拉水箱。

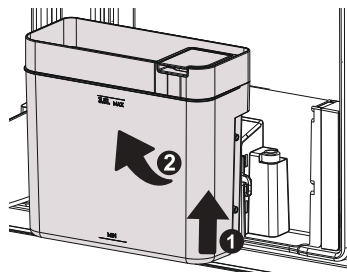

拆除水箱

3. 拆除水箱蓋 (1)，水箱管 (2) 和過濾器 (3)。

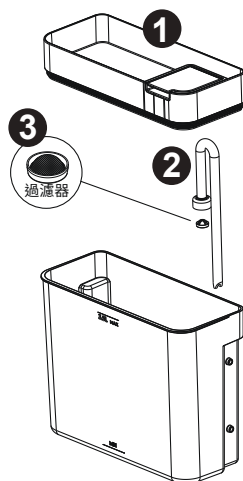

拆卸水箱

執行相反步驟以組裝水箱並返回原位。執行相反步驟以組裝水箱並返回原位。

註：僅限 EQE5660 型號的水箱

冷凍室儲存

拆除冷凍室抽屜：

所有冷凍室抽屜均可拆除。

1. 完全打開櫃門，找到抽屜。
2. 拉出抽屜直至達到止動器。抬起並拉出，將其從櫃體上取下。
3. 反向操作上述步驟即可重新裝回抽屜。

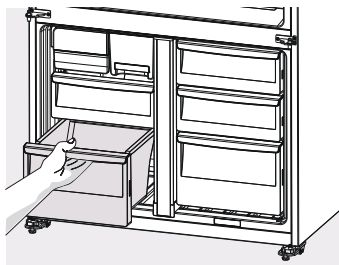

拆除冷凍室抽屜

旋轉出冰式冰盒（僅限 EQE5600 型號）：

1. 首次使用前，清潔冰盤。
2. 加水至冰盤內最大水位。

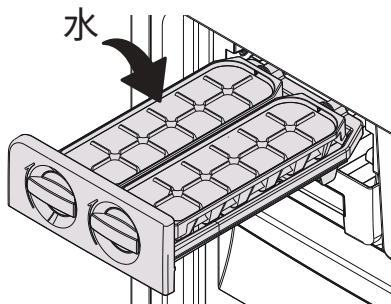

3. 放入冰盤。
4. 順時針旋轉冰塊以釋放冰盤中的冰塊。

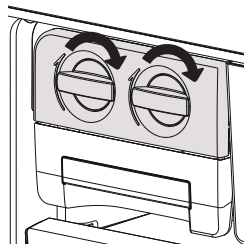

6. 自動冰水機

註：僅限 EQE5660 型號的自動冰水機

安裝後使用製冰機

自動製冰機從位於雪櫃內的水箱中抽水並將其分配到雪櫃的自動製冰機中。

然後冰塊將落入製冰機下方的冰盒中。如果水箱是空的或低於水位線，製冰機將在 3 次嘗試從水箱中抽水後自動關閉。使用者介面上的製冰機指示燈顯示製冰機的運行狀態（參閱控制器說明）。

水箱加水

- 水箱必須位於櫃門上。
- 透過水箱蓋上的漏斗倒入飲用水。
- 確保製冰機和飲水機均已開啟。

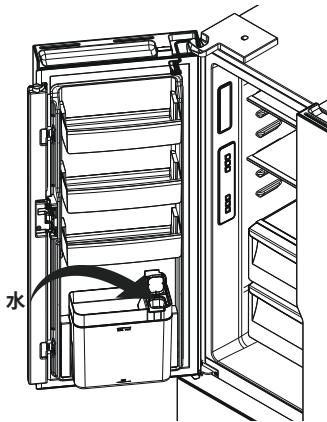

啟動供水系統

1. 將水杯壓向飲水機並保持，即開始取水。
2. 將水杯固定在此位置，直至水從飲水機中流出。
注滿大約需要一分半鐘。
3. 繼續放水約四分鐘以沖洗系統和管道連接處的任何雜質（必要時停下來清空玻璃杯）。

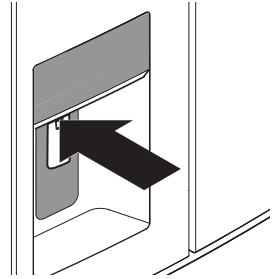

註：飲水機帶有一個內置裝置，連續使用三分鐘後會關閉水流。要重設此關閉裝置，只需鬆開飲水機槳葉即可。



注意

切勿將清潔水（過濾水或礦泉水）以外的任何液體加入水箱。汽水、果汁、茶或熱水等可能會損壞您的自動製冰機。水箱可承受最高 60°C 的水溫



使用貼士與有用資訊

每月拆下並清潔一次冰盒和水箱，丟棄未使用的冰塊和水。這將確保始終有新鮮冰塊和製冰機順利運行。
確保雪櫃水平放置，以避免冰塊大小不均勻。

開啟或關閉製冰機



重要

製冰機在出廠之時已經開啟，因此一旦雪櫃安裝完畢即可使用。如果沒有加滿水箱，請將製冰機的開/關功能設為關；否則，製冰機的注水閥在嘗試無水運行時可能會發出很大的噪音。

製冰由製冰機控制面板上的開/關功能控制。按下開/關功能可開啟或關閉製冰機。

註：製冰機還有一個內置塑膠信號臂，當冰盒裝滿時，它會自動停止製冰。此信號臂不可用於手動停止製冰機。



重要

關閉製冰機就會停止製冰。您仍可取用現有冰塊或水。

製冰機/飲水機貼士

- 當製冰機在運行時，發出以下聲音屬於正常現象：
 - 電機運行
 - 冰塊落入冰盒
 - 水閥開啟或關閉
 - 流水



注意

如果進入雪櫃的水經過軟化，請確保正確維護軟水劑。來自軟水劑的化學物質會損壞製冰機。

清潔製冰機

定期清潔製冰機和冰盒，尤其是在度假或搬家之前。

1. 關閉製冰機。
2. 直接向外拉出即可拆除冰盒。
3. 清空冰盒，用中性清潔劑清洗冰盒。請勿使用刺激性或研磨性清潔劑。請勿將冰盒放入洗碗機。用清水沖洗。
4. 重新裝入冷凍室之前，應徹底晾乾冰盒。
5. 重新放回冰盒。打開製冰機。

7. 一般資訊

7.1 清潔雪櫃



警告

清潔前：關閉雪櫃的電源，拔下電源插頭，以防止觸電。

不鏽鋼：

此雪櫃採用抗痕不鏽鋼製造。這種不鏽鋼擁有一層特殊的高級保護塗層，可以輕鬆去除指紋和水漬等痕跡。為保持其乾淨外觀，應定期用溫和肥皂水和軟布清潔。



注意

切勿使用不鏽鋼清潔劑、研磨墊或其他會劃傷表面的清潔劑。交付後對本機的損壞不在保固範圍內。

內飾

定期用軟布、無味的溫和肥皂和溫水清潔雪櫃內部。徹底擦乾所有表面和可拆卸部件，避免控制器沾水。裝回可拆卸部件，插入電源並打開電源，然後再放回食物。

櫃門密封

始終用溫和的清潔劑和溫水清洗門封條，然後徹底乾燥，以保持門封條清潔。當您打開櫃門時，黏性食物和飲料會導致密封件黏在櫃門上並劃破。

切勿使用熱水、溶劑、商用廚房清潔劑、氣溶膠清潔劑、金屬拋光劑、腐蝕性或研磨性清潔劑或擦洗劑清潔雪櫃。許多市售清潔產品和清潔劑都含有會損壞雪櫃的溶劑。只能使用塗抹無味溫和肥皂和浸潤溫水的軟布。



注意

要清潔帶有伸縮式擴展滑軌的保鮮格或冷凍室盒，只需用濕布和溫肥皂水擦拭即可。切勿將蓋子浸入水中，因為這可能會影響滑塊的操作。

關閉雪櫃

如果要長時間關閉雪櫃，請按照以下步驟減少黴菌滋生的機會：

1. 清空食物。
2. 從插座拔掉電源線。
3. 徹底清潔並乾燥雪櫃內部。
4. 確保將所有櫃門稍微楔開，以便空氣流通。

7.2 空氣過濾器

空氣過濾器位於冷藏室的頂部中間位置。

更換空氣過濾器

為確保最大程度濾除雪櫃內的異味，應每六個月更換一次空氣過濾器（觸控螢幕上的過濾器狀態燈會提示您在六個月後更換過濾器）

1. 將蓋的兩側擠壓在一起並從襯裡上取下，取下空氣過濾器蓋。
2. 取下舊過濾器並將其丟棄。
3. 打開新過濾器的包裝並將其滑入外殼。過濾器的開面（碳介質）應安裝在多流道的通風口（孔）上。
4. 擠壓側面並將其卡回原位即可裝回空氣過濾器蓋。
5. 按住控制面板上的「Reset Air Filter」（重設空氣過濾器）按鈕三秒鐘。當 LED 熄滅後，狀態將復位。

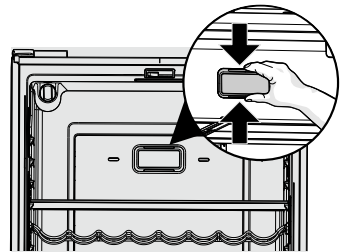

7.3 冰塊與水（可選型號）

定期用軟布和溫和肥皂水清潔製冰機/飲水機並用溫水徹底沖洗乾淨。欲詳細了解製冰機、飲水機取冰器的保養和清潔，請參閱「製冰機和飲水機型號」部分。

7.4 水箱

水箱只能在清潔時取下，只能填充飲用水，水箱必須放在櫃門上，並且必須使用蓋子上的漏斗加水。

定期用軟布清潔水箱內部，用軟刷清潔過濾器，並用溫水徹底沖洗以徹底清除任何皂液殘留物。

註：當客戶將水箱組裝到櫃門時，為避免漏水，請確保水箱噴嘴與外殼插座完全接合。

8. 食物存放指南

類別	產品	新鮮食物的建議儲存時間*			存放貼士
		雪櫃	TasteSeal Plus	冷凍室	
肉類	香腸和肉餡	1-2 天	3-5 天	2-3 個月	把冷凍肉放在雪櫃後面最冷的地方。 如果在雪櫃中存放超過一天，塑膠袋會導致肉出水。 烤肉可能需要長達 48 小時才能正確解凍，使用前 2 天將冷凍烤肉轉移到冷藏室中。
	豬排與牛排	3-4 天	5-7 天	4-6 個月	
	冷凍肉	3-5 天	5-7 天	4-6 個月	
	烤肉	3-5 天	1 週	12 個月	
禽肉	雞肉	1-2 天	5-7 天	2 個月	如果禽肉有您不確定的氣味或顏色，最好將其丟棄。 全蛋不適合冷凍，稍微打散的雞蛋可以冷凍四個月。
	烤雞	3-5 天	1 週	12 個月	
	雞蛋	6 週	不適合	不適合	
海鮮	整條魚和魚片	2-3 天	5-7 天	2 個月	儲存在密封容器或箔紙中。 切勿在鹽水中冷凍對蝦，因為這會使蝦肉脫水。
	龍蝦與螃蟹	1-2 天	3-5 天	2 個月	
	對蝦	1-2 天	3-5 天	2 個月	
乳製品	牛奶	保質期內	不適合	不適合	如果乳製品有您不確定的氣味或顏色，最好將其丟棄。 根據品種的不同，硬奶酪可以保存 2 週到 2 個月 * 質地可能會根據軟奶酪的類型而不同
	酸奶	7-10 天	不適合	不適合	
	硬奶酪	2 週 -2 個月	1-2 個月	2 個月 (分格)	
	軟奶酪	1-2 週	2-4 週*	不適合	
	黃油	8 週	3-4 個月	12 個月	
水果與蔬菜	每種水果與蔬菜都有不同的保質期。有些僅可以保鮮數天 (例如豆子)，有些可以保鮮幾個月 (例如洋蔥)。		不適合	8-12 個月 冷凍時切成小份，焯水。	將蔬菜放在保鮮格中並遠離通風口，以免結冰。
					在儲存水果和蔬菜之前，如果您已經清洗過，請確保它們是乾燥的，或在放入雪櫃之前用吸水紙包裹，因為水分会使它們更容易腐爛。
					儘量將水果和蔬菜分開，因為會釋放大量乙烯 (催熟劑) 的水果會加快周圍蔬菜的成熟和腐爛
剩菜剩飯	家庭自製食物	3-4 天	不適合	2-6 個月	存放在密封容器內。
					分小份食物冷凍以減少浪費。

**重要**

請注意，此資訊僅供參考，實際儲存時間會因您使用雪櫃的方式、氣候條件和食物的新鮮度而異。

9. 故障排查

設備未在理想溫度下運行

在現代無霜雪櫃/冰櫃中，透過高效風扇使冷空氣流經通風口並在各個隔室周圍循環。

問題	解決方案
雪櫃溫度過高	<ul style="list-style-type: none"> 將雪櫃溫度調節至較冷設定 確保食物完全冷卻後再放入雪櫃內。 確保根據說明設定設備 確保沒有異物阻塞冷卻通風口。 確保櫃門沒有打開，或避免頻繁打開。
冷凍室溫度過高	<ul style="list-style-type: none"> 調節至較冷設定。 確保食物完全冷卻後再放入冷凍室內。 確保根據說明設定設備 確保沒有異物阻塞冷卻通風口。 確保櫃門沒有打開，或避免頻繁打開。
食物在雪櫃內結冰	<ul style="list-style-type: none"> 調節至較暖溫度。 確保水果和蔬菜儲存在保鮮格內。含水量高的食物不應放在冷卻通風口附近。
無法改變溫度設定	<ul style="list-style-type: none"> 參閱「溫度控制」和「關於使用者介面」部分。 在嘗試調整溫度之前，確保使用者介面處於「喚醒」模式。

設備噪音

此新雪櫃可能會發出舊設備沒有的聲音。因為這是與之前不同的聲音，因此您可能會質疑。大部分聲音都是正常的。堅硬的表面，如地板、牆壁和櫥櫃，會使聲音聽起來比實際更響亮。以下說明聲音類型和可能產生噪聲的來源。

問題	解決方案
電機噪音（壓縮機）	<p>正常這是正常現象，因為您的新雪櫃使用高速壓縮機，它會在運行期間打開和關閉。</p> <p>注意，在啟動階段壓縮機噪聲聽起來可能比平時更響亮。</p>
電機噪音（壓縮機）	<p>雪櫃配備了變速壓縮機和風扇。在啟動時和溫度較高的環境下，它們會以更高的速度運行以提供更多冷卻。當不需要過多冷卻時，壓縮機和風扇將以較低的速度運行。因此，噪聲水平根據運行條件而變化是正常現象。</p>
在壓縮機開始運轉之前會聽到咔嚓聲	<p>正常這是正常現象，因為此新雪櫃會自動切換溫度控制，開啟和關閉壓縮機。</p>

問題	解決方案
偶爾出現嗡嗡聲，類似於水煮開時的聲音	<p>正常每當循環結束時，您可能會聽到由於冷凍劑在雪櫃系統中流動而發出的嗡嗡聲。</p> <p>沒問題，這是正常的，因為新雪櫃採用高效能風扇來進行空氣循環。在使用量大或較熱天氣下，風扇速度與噪聲可能會增加。</p>
嘎嘎聲和其他噪聲。	<ul style="list-style-type: none"> 確保雪櫃平穩固定在地面，參閱安裝說明 檢查設備的周圍環境，確保沒有任何東西接觸或放置在設備頂部。 確保設備內的物品穩定，不會發生搖晃（例如瓶子）。

保鮮格操作

問題	解決方案
保鮮格內聚集水分 保鮮盒內聚集一些水汽和濕氣是正常現象。	<ul style="list-style-type: none"> 確保保鮮格不要塞得太滿。 調節保鮮格濕度滑塊。
保鮮盒可以拆除。	<ul style="list-style-type: none"> 如果保鮮盒阻擾了雪櫃門儲物盒，請在拆除保鮮格之前先拆除雪櫃門儲物盒。 放入櫃箱內，以便可以完全打開櫃門。
保鮮格內的物品結冰	<ul style="list-style-type: none"> 調節至較暖溫度。

雪櫃運行

問題	解決方案
雪櫃不運行 在自動除霜期間，或在設備開啟後的短時間內，冷凍室的風扇不會運行，這是正常現象。	<ul style="list-style-type: none"> 確保將電源插頭插入已通電插座。 確保家用斷路器未跳閘或保險絲未熔斷。 設備可能處於除霜模式，半小時後再檢查。
壓縮機電機似乎長時間運行 在正常室溫下，預計電機將在大約 40% 到 80% 的時間內運行。在較熱天氣下，預計運行時間會更長。	<ul style="list-style-type: none"> 確保雪櫃門未打開。 檢查是否放入了大量尚未完全冷卻的食物。 注意，設備在最初安裝後，或剛剛調節溫度設定後可能不會正常運行。

問題	解決方案
<p>壓縮機電機似乎長時間運行。這些電器使用變速壓縮機，設計可以長時間運行，這是正常現象</p>	<ul style="list-style-type: none"> • 因為您的新雪櫃使用變速壓縮機和風扇，在啟動時和氣溫較高的環境下會高速運行以提供額外的冷卻。當不需要過多冷卻時，壓縮機和風扇將以較低的速度運行，但仍可能不會關閉。這是正常現象。 • 壓縮機和風扇僅可能在雪櫃除霜時停止運作，大約每天一次。
<p>此時觸摸設備外殼會感覺很熱</p> <p>這是正常現象，因為設備透過外殼面板和櫃門之間的分割器將內部的熱量傳遞至外部。</p>	<ul style="list-style-type: none"> • 確保設備周圍的間隙符合「安裝新設備」部分中的建議距離。 • 在較熱天氣裡，機櫃的外部會更熱，甚至可能會感覺燙手，這是因為電器正在高速工作。
<p>使用者介面無響應</p> <p>為避免在無意中變更設定，使用者介面將在不使用時進入休眠模式。按下任意按鈕即可喚醒使用者介面</p>	<ul style="list-style-type: none"> • 檢查使用者介面是否處於喚醒模式，參閱「關於使用者介面」部分。 • 檢查使用者介面是否鎖定，參閱「關於使用者介面」部分。 • 如果使用者介面被凍結，請關閉設備五分鐘以清除記憶，然後重新開啟。
<p>警報聲</p>	<ul style="list-style-type: none"> • 檢查所有櫃門是否完全關閉。 • 確保冷凍室中的熱食不會觸發超溫警報。 • 檢查飲品定時器是否計時結束，參閱控制說明。
<p>結霜</p>	<ul style="list-style-type: none"> • 檢查所有櫃門是否完全關閉。 • 確保雪櫃門未頻繁打開。 • 確保回風口沒有被包裝物堵塞。 • 確保密封件乾淨且未堵塞。
<p>異味</p>	<ul style="list-style-type: none"> • 內部可能需要清潔，請參閱清潔指南。 • 確保正確儲存食物，因為某些食物、容器和包裝材料會產生異味。 • 檢查設備內是否有過期或不尋常的食物。
<p>照明燈不亮</p> <p>LED 燈設計為可緩慢點亮。LED 燈會在櫃門打開超過 5 分鐘後自動減弱，超過 7 分鐘後自動熄滅。關閉櫃門將重設計時器。</p>	<ul style="list-style-type: none"> • 確保將電源插頭插入已通電插座。 • 確保家用斷路器未跳閘或保險絲未熔斷。 • 查看設備功能部分以確定適合您的機型的照明配置。

櫃門操作

問題	解決方案
冷凍室內櫃門打開。	<ul style="list-style-type: none"> 這是正常現象，需要重新關閉。當雪櫃門關閉過快時，會出現此情況。 如果冷凍室門保持打開狀態，則表明雪櫃需要再向後傾斜一點。參閱「安裝新設備」部分。
無法自動關閉。	<ul style="list-style-type: none"> 檢查設備是否有自動關閉鉸鏈，並非所有型號都有此裝置。 則表明雪櫃需要再向後傾斜一點。參閱「安裝新設備」部分。
櫃門密封不佳	<ul style="list-style-type: none"> 確保沒有任何物品阻止櫃門關閉，例如雪櫃內的食物或放置在雪櫃附近的物品。 確保保鮮格/冷凍盒完全關閉。必要時，請按照「使用雪櫃」一節中的說明重新安裝。 確保根據建議安裝雪櫃。
櫃門難以打開或關閉	<ul style="list-style-type: none"> 如果在櫃門在關閉後很難打開，這是由於壓力正在平衡，幾分鐘後櫃門即可正常打開。

如仍需服務

若您遇到問題，且在完成上述檢查之後問題仍然存在，請聯絡您最近的 Electrolux 授權服務中心，或您購買本產品的經銷商。請提前準備好型號，9 位 PNC 碼及 8 位序列號，其位於雪櫃內部的標籤上。

10. 噪聲

設備噪音

此新雪櫃可能會發出舊設備沒有的聲音。因為這是與之前不同的聲音，因此您可能會質疑。大部分聲音都是正常的。堅硬的表面，如地板、牆壁和櫥櫃，會使聲音聽起來比實際更響亮。以下說明聲音類型和可能產生噪聲的來源。

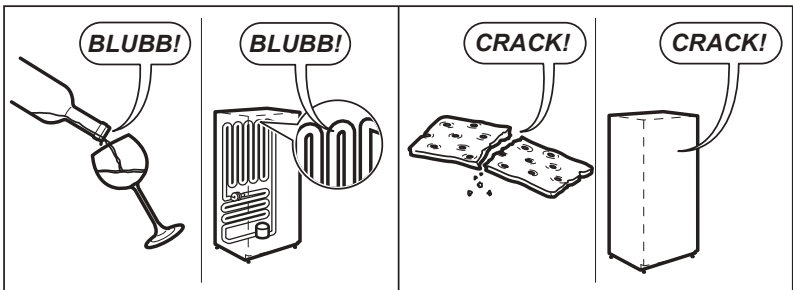
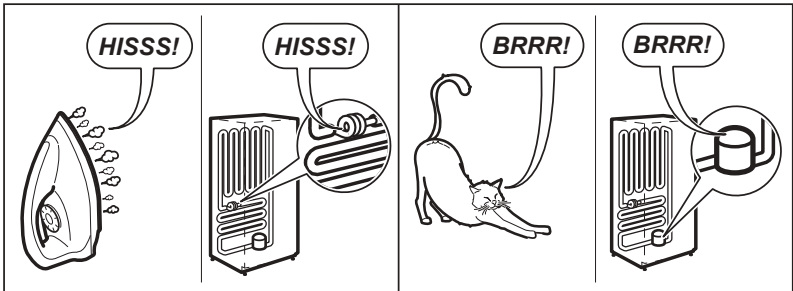
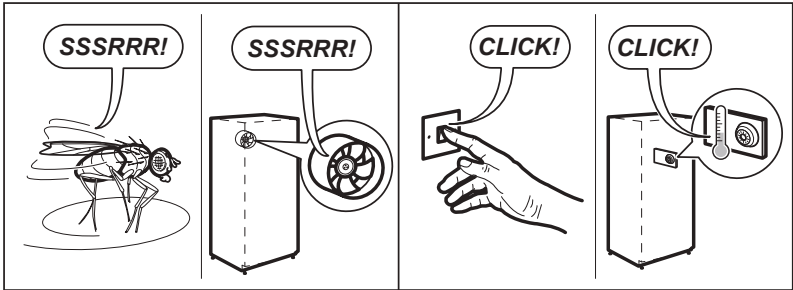
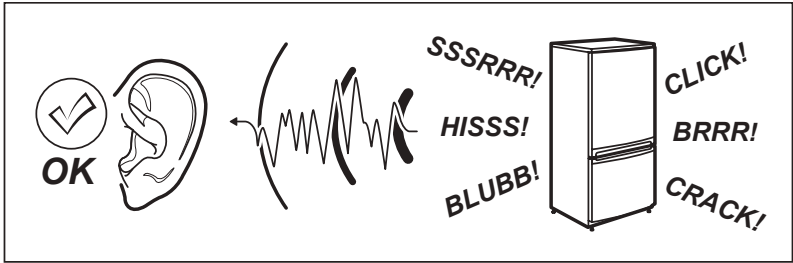

NOTE

NOTE

www.electrolux.com/shop



CONTACT DETAILS ELECTROLUX CUSTOMER CARE

Philippines

Domestic Toll Free: 1-800-10-845-care 2273
Hotline No: (02) 8845-2273 (02) 8845-4663
Electrolux Philippines, Inc.
12/F Cyber Sigma Bldg., Lawton Avenue,
McKinley West, 1634 Taguig City, Philippines
Email: wecare@electrolux.com

Hongkong

DCH ELECTRICAL APPLIANCES SERVICE CENTRE
4/F, DCH BUILDING, 20 KAI CHEUNG ROAD,
KOWLOON BAY, HONG KONG
SERVICE HOTLINE: (+852) 3193 9888
EMAIL: customer-care@dch.com.hk

Malaysia

Electrolux Home Appliances Sdn. Bhd.
Lot C6, No. 28, Jalan 15/22,
Taman Perindustrian Tiang Nam Seksyen 15,
40200 Shah Alam, Selangor.
Customer Care Hotline: 1300-88-1122
Email: malaysia.customer-care@electrolux.com
Website: www.electrolux.com.my

Singapore

CONSUMER CARE HOTLINE : (+65) 67273699
Electrolux S.E.A. Pte Ltd.
351 Braddell Road, #01-04 Singapore 579713
Office Fax: (+65) 67273611
Email : customer-care.sin@electrolux.com

A24336504-A-082023

